

# Intelligent Traffic Management and Parking Space Detection Using Raspberry Pi and Internet of Things

<sup>1</sup> Zain Rajani, <sup>2</sup> Michelle Araujo e Viegas

<sup>1</sup>UG Student <sup>2</sup> Head of Department

<sup>1,2</sup> Electronics and Telecommunication

<sup>1,2</sup> Don Bosco College of Engineering, Fatorda, Margao, Goa, India

---

**Abstract –** In today's world Internet of Things (IOT) has important role to play in communication between the environmental things and the sensor or network which made access to data or monitoring the conditions from any remote location. The project is designed to manage the traffic signals and the traffic congestion situation on roads along with finding the parking slot detection. In this system, we make use of sensor such as PIR, IR to find the intensity of traffic present on roads and to finding the parking slot detection respectively. All the sensors are incorporated with Raspberry Pi which helps in control of traffic lights and monitors the empty parking slot available and the parameters measured are intimated to the user. With the help of this system one can clear the traffic without any kind of delays.

**Keywords:** Internet of Things (IOT), Parking system, Raspberry Pi, Sensors, Traffic Intensity.

---

## I. INTRODUCTION

In recent years traffic congestion is became a major problem because a lot of time is wasted in waiting for a signal unnecessary. Due to increase in number of vehicles, road structures and malfunctioning of signaling system are some of the main reasons for traffic congestion. Poor signal timing means the traffic that occur due to the signal which is been use. Under the present conditions traffic control is achieved by the use of system of a fixed time for which the signal turns the green signal on and allows the passage of the vehicles. But the current conditions are that they cannot find which lane has more vehicle intensity inorder to reduce the traffic congestion. The traffic congestion could be due to repairing of roads or due to accidents, etc.

In the recent years many research have been done based on Internet of Things (IOT) and there is no common architecture for the same till today [1]. Also depending on the application IOT has different and various definition. If in general terms we want to define it could be defined as the things present in the physical world or in an environment are attached with sensors or with any embedded system and made to connect to the network which could be connected either wireless or using wired connection [2, 3]. The wired communication can be costly and also be difficult to maintain. The devices connected to such a network are called as smart devices which communicate with a server or a device to human and vice versa. Important benefits of Internet of Things (IOT) are: Tracking behavior of the sensor can monitor various situations, sensor driven analysis, fast and better control and response, etc. IOT technology is growing day by day and is finding its application in many areas. Any Internet of things (IOT) system involves the following operation of sensing, processing and connectivity.

In today's world many people are moving to urban areas so the cities are crowed with people and this also creates problems for themselves. As many people use transportation system and have to deal with transportation issues in searching for parking area to park their vehicles. The system proposed here not only finds the traffic intensity but also helps in finding the empty parking slot available in particular area. The system uses Raspberry Pi which is going to be the main part of the system. The system overview is shown in Fig.1.

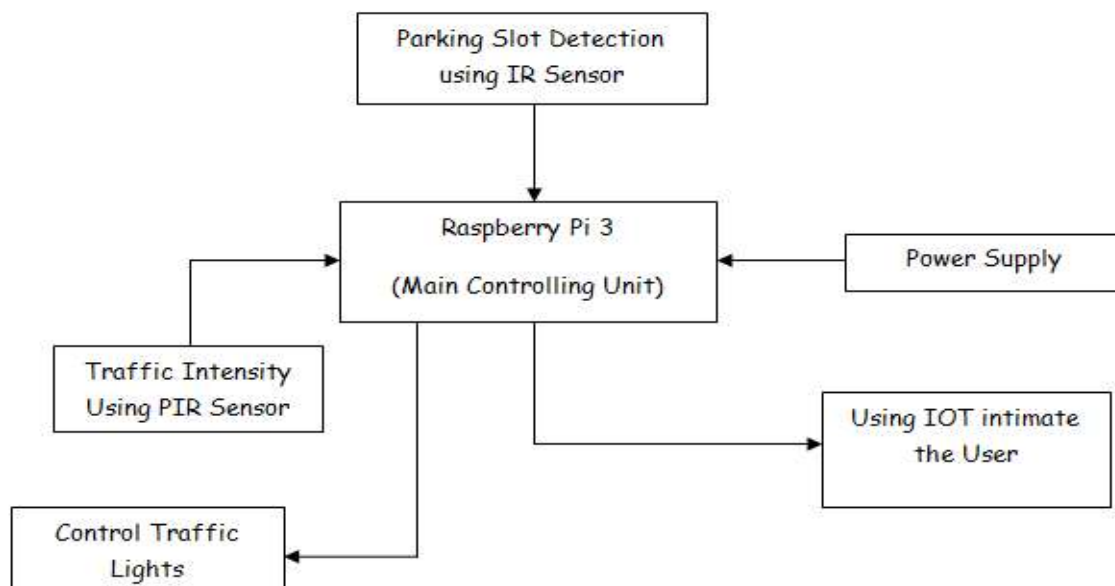

Fig. 1: Block Diagram for Management of Traffic

Since Raspberry Pi is the main part of the system it receives its power from any 5 V source such as android charger which will activate the system and make it ready for processing. The IR sensor is basically used to detect if the car is present or not and it is an active sensor and it sends the IR and if the IR sensor is interrupted it detects that car is present and does the necessary processing. The Output that is being generated is around 2.98 V which is sufficient to operate the Raspberry Pi and hence no potential divider is required. The PIR sensor works also on the same principle the difference being that it is a passive device. Depending upon the results obtained from the sensors the traffic lights are controlled and the user will be intimated using IOT.

## II. HARDWARE REQUIREMENTS:

### A. Raspberry Pi 3:

The Raspberry Pi which is a microcomputer has extensive features at a lower cost. It has 17 GPIO (General Purpose Input Output) pins which give out 3.3V. The device uses the ARM processor which does most of the hard work in order to run the Raspberry Pi. ARM processors can be thought of as the brains of the device.

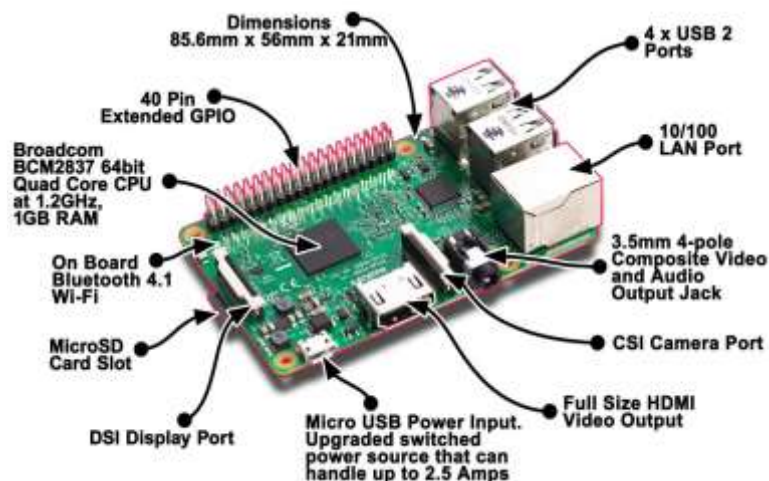

Fig.2: Raspberry Pi 3

The Raspberry Pi is connected to PC via software called PUTTY. The PUTTY establishes the connection and helps to enter into the Kernel Shell and program the Raspberry pi. The coding of Raspberry Pi is done using Python programming language. PuTTY allows you to communicate to Raspberry Pi directly.

### B. IR Sensor:

Infrared technology addresses a wide variety of wireless applications. The main areas are sensing and remote controls. In the electromagnetic spectrum, the infrared portion is divided into three regions: near infrared region, mid infrared region and far infrared region. The frequency range of infrared is higher than microwave and lesser than visible light. An infrared sensor emits and/or detects infrared radiation to sense its surroundings. The working of any Infrared sensor is governed by three laws: Planck's Radiation law, Stephen – Boltzmann law and Wien's Displacement law.

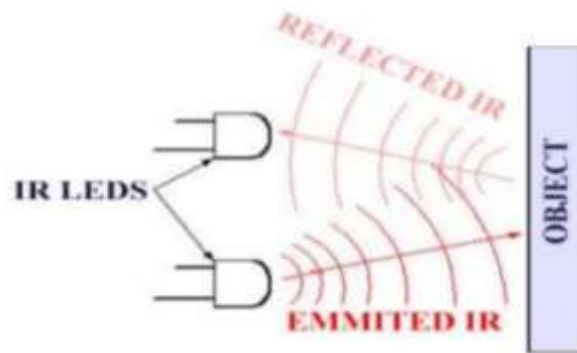

Fig. 3: Operation of IR Sensor

The basic concept of an Infrared Sensor which is used as Obstacle detector is to transmit an infrared signal, this infrared signal bounces from the surface of an object and the signal is received at the infrared receiver. Infrared sensors can be passive or active. Passive infrared sensors are basically Infrared detectors. Active infrared sensors consist of two elements: infrared source and infrared detector. When operated at a supply of 5V, the IR transmitter consumes about 3 to 5 mA of current. The most commonly used modulation is OOK (ON – OFF – KEYING) modulation. An IR sensor consists of an IR LED and an IR Photodiode; together they are called as Photo – Coupler or Opto – Coupler. The basic principle working of IR sensor is shown in Fig. 3.

#### C. PIR Sensor:

PIR stands for Passive Infrared. This motion sensor consists of a Fresnel lens, an infrared detector, and supporting detection circuitry. The lens on the sensor focuses any infrared radiation present around it toward the infrared detector. Our bodies generate infrared heat, and as a result, this heat is picked up by the motion sensor. The sensor outputs a 5V signal for a period of one minute as soon as it detects the presence of a person. It offers a tentative range of detection of about 6-7 meters and is highly sensitive. When the PIR motion sensor detects a person, it outputs a 5V signal to the Raspberry Pi through its GPIO and we define what the Raspberry Pi should do as it detects an intruder through the python coding.

The sensor converts the resulting change in the incoming infrared radiation into a change in the output voltage, and this triggers the detection. Objects of similar temperature but different surface characteristics may also have a different infrared emission pattern, and thus moving them with respect to the background may trigger the detector as well. Fig. 4 shows the working of the sensor.

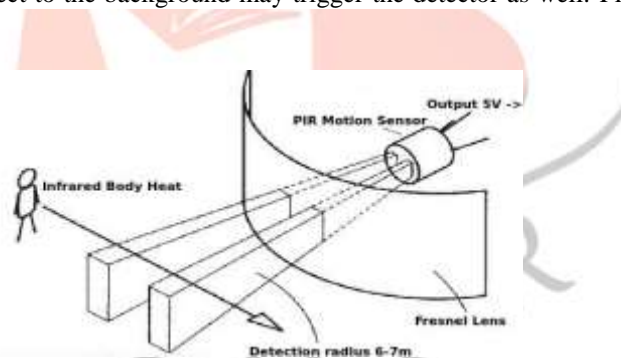

Fig. 4: Principle Operation of PIR Sensor

### III. CIRCUIT DESIGN

#### A. Connecting PIR Sensor:

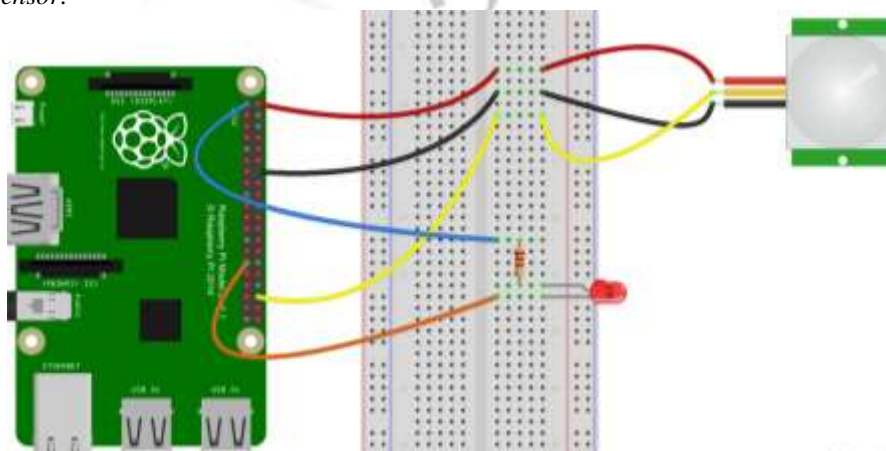

Fig. 5: PIR Sensor Connection

The Fig. 5 shows the connection for the PIR sensor. The pins connected to raspberry pi and the PIR provide the necessary signal to and fro from the raspberry pi. If the intensity of traffic increases then the red LED starts to blink indicating there is heavy traffic for the travelling towards that path and also will notify the travelers along that path.

#### B. Connecting IR Sensor:

The fig. 6 shows the connection for determining the parking space available. The output obtained from the sensor is of a nominal value hence no external circuit is required. For demonstration we have shown only one parking slot. The output of which is shown using LED the number of LED on will indicate the parking space available in the area and the same information will be passed to traveler present in that area.

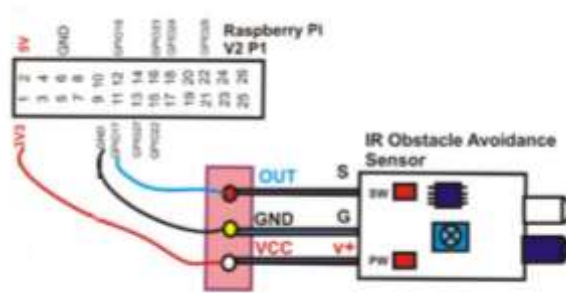

Fig. 6: IR Sensor Connection

**IV. ALGORITHM AND FLOWCHARTS**

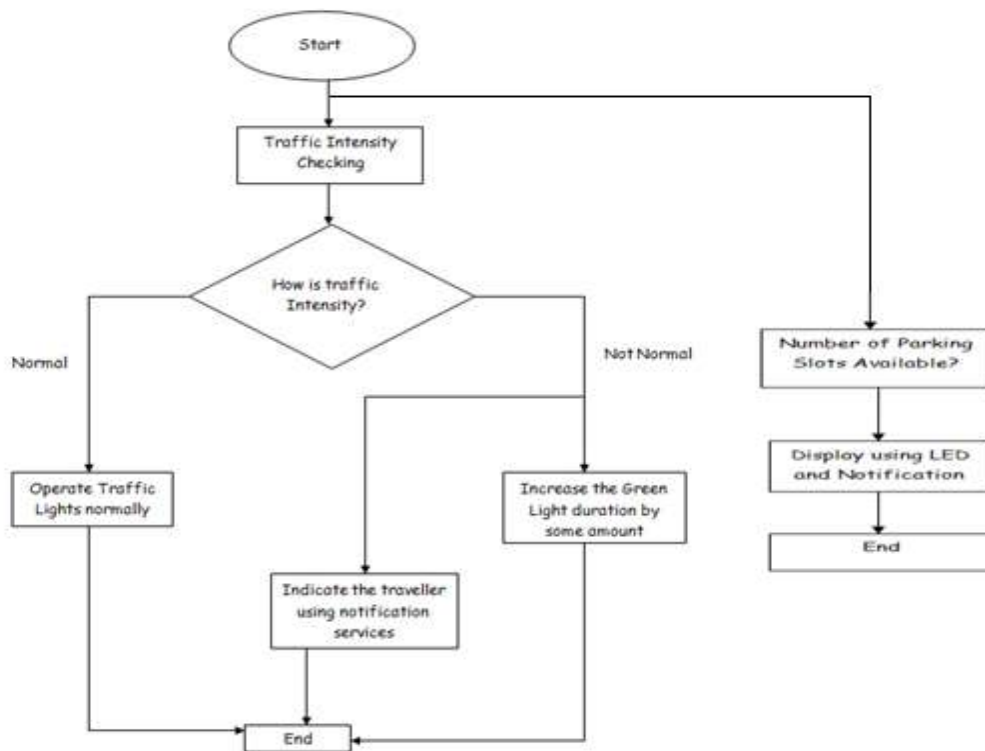

Fig. 7: Flow Diagram for Traffic Intensity and Parking space detection

**V. RESULT AND DISCUSSION**

The project is aimed in providing simple and efficient way for providing solution to the traffic problem being faced in today's world. For the project the first thing is that we have to make all the input and outputs ready and available for sensing and processing of data. The fig. 9 shows the entire circuit being implemented for the project. The circuit has proved to be working as per the requirement and can be used on large scale. The problem that was been seen while the execution was that the sensor would be easily interfered when human passes in front of the sensor. The Fig. 10 and Fig. 11 shows the notification sent to the traveler for parking space and traffic intensity respectively.

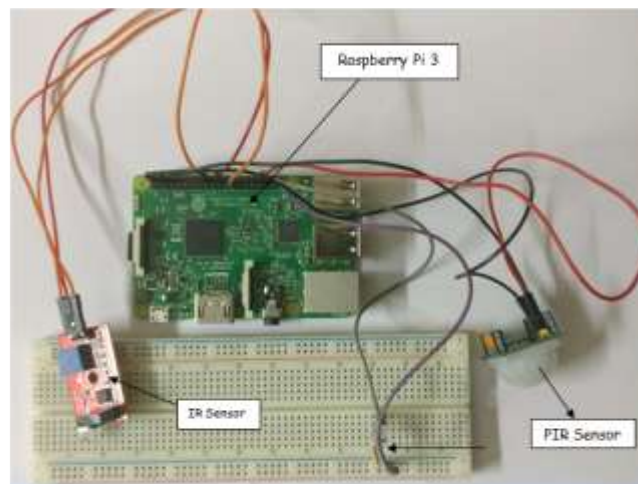

Fig.9: Practical Circuit Implementation

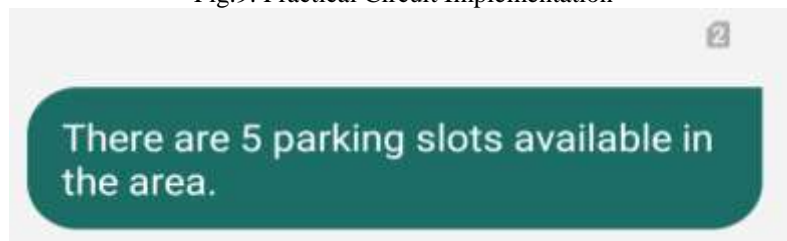

Fig 10: Alerting the user via SMS for Parking space

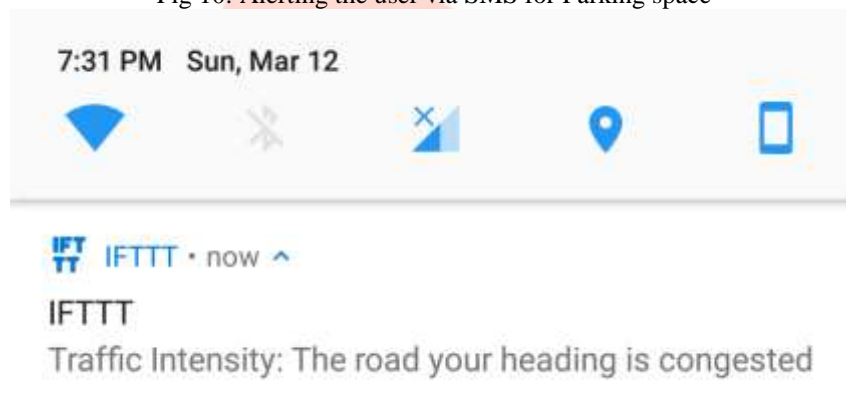

Fig. 11: Notification for Traffic Intensity

## V. CONCLUSION

This paper provides a design for measuring the traffic intensity and parking space management in transportation system. When the cars cross the PIR sensors the cars are counted and depending upon the number of cars crossed the traffic lights are controlled. The problem with traffic system is that if the intensity of cars are more on more than one side of the junction then the system might fail and also in the similar way the car waiting at other side of junction may have to wait for longer time as the traffic intensity is less which would result in waste of time. In practice currently in India we are following time based traffic control signals and we are suffering from heavy traffic jams. The parking slot detection is found to be efficient but with small amount of errors. The work presented could be improvised if a magnetic sensor is used for finding the intensity and also it could be used along with finding the amount that the traveler has to pay when he parks in pay and park areas. The system being wireless is cheap for installation and maintenance is easy. The approaches can be implemented practically so that the restriction we are facing with present technique can be overcome.

## VI. REFERENCES

- [1] L. Atzori, A. Iera, and G. Morabito, "The Internet of things: a survey," *Computer Networks*, vol. 54, no. 15, pp. 2787-2805, 2010.
- [2] Kaivan Karimi and Gary Atkinson, —What the Internet of Things (IoT) Needs to Become a Reality, White Paper, FreeScale and ARM, 2013.
- [3] M. Albano, A. Brogi, R. Popescu, M. Diaz, and J. A. Dianas, "Towards secure middleware for embedded peer-to-peer systems: Objectives and requirements," in *RSPSI '07: Workshop on Requirements and Solutions for Pervasive Software Infrastructures*, 2007, pp. 1– 6. [Online]. Available: <http://citeseerx.ist.psu.edu/viewdoc/download?doi=10.1.1.90.5982&rep=rep1&type=pdf>
- [4] Amrita Rai and Govind Singh Patel, "Multiple Traffic Control Using Wireless Sensor and Density Measuring Camera", *Sensors & Transducers Journal Vol. 94, Issue 7, July 2008*, pp. 126-132.
- [5] <https://www.scribd.com/doc/37669227/Density-Based-Traffic-Light-Control-System>



- [6] Mr. Basavaraju S R, “Automatic Smart Parking System Using Internet of Things (IOT)”, International Journal of Scientific Research Publications, Volume 5, Issue 12, December 2015, pp.628-632
- [7] <http://www.circuitdigest.com>

