

# Design and implementation of servo voltage stabilizer for commercial and industrial application

<sup>1</sup>Rahul govind jadhav, <sup>2</sup>Neha naresh varunkar, <sup>3</sup>Vasant suresh tirodkar, <sup>4</sup>Gauri subhash daddikar, <sup>5</sup>Mestry sachin shankar  
<sup>1</sup>Student, <sup>2</sup>Student, <sup>3</sup>Student, <sup>4</sup>Student, <sup>5</sup>Assistant Professor  
 SSPM college of engineering, kankavli

**Abstract** - It is an industrial project to study servo controlled voltage stabilizer. Since the voltage fluctuation comes in power system and equipment. There are many problems produced in line voltage like distortion, fluctuation, heating, noise, accuracy power rating, voltage range (230+/-5%) and power capacity less than 600 VA. Due to these problems daily use equipment are at peril like fan, laptop, cooler and refrigerator. To solve these problems we use voltage stabilizer before the equipment for protection mainly two types of stabilizes are present in the market world, one is automatic or line voltage stabilizer and other is servo voltage controlled stabilizer. In case of servo voltage stabilizer, different types of power problems are beat with voltage range (230+/-1%) and power capacity up to 1000 KVA. so several technical recall related to the digital servo controlled voltage stabilizer and technology have been reduced.

## INTRODUCTION:

The servo controller voltage stabilizer "SCVS" is designed to give a constant output voltage where stable utility power is important. SCVS consists of Auto Transformer, Buck boost Transformer AC Synchronous servo motor and associated control circuitry. It provides a stable output voltage for a finite input fluctuation.

Servo controlled voltage stabilizer (SCVC) maintains accurate output to feedback controlling motor. The input is connected series with secondary winding of a buck boost transformer. The secondary will get additive or subtractive voltage induced from the primary. When the input voltage is low then secondary will have additive voltage to give boosted output vice versa. The primary of these buck boost transformer is connected to the fixed tap and the variable point of the auto-stat is connected to the input supply.

The position of variable point with respect to the fixed tap point. Determine the amount of primary voltage and thereby the secondary voltage of the transformer which become additive or subtractive. Thus the input is boosted or bucked by the series connected secondary winding correspondence to the position of variable point is driven by the servo motor in the forward or reverse directions. The forward or reverse signal is given through a controller circuit which is energized by an output sensing transformer.

The control circuit will be giving forward reverse signal to the motor till the output is connected to required value as sensed by the sensing transformer, if the variations in the input voltage goes beyond the specific range, the brush arm of the auto-stat will be driven to either the of the ends, thus not able to correct output further. This however is likely to cause damage to the auto-stat, motor etc. To avoid the same limit switches are provided at both the ends of the auto-start winding, so that the brush arm on reaching the end will automatically cut off the supply to the motor, and prevents further movements. The indications will be given LEDs, to enunciate over or under voltage condition.

## PROBLEM IDENTIFICATION:

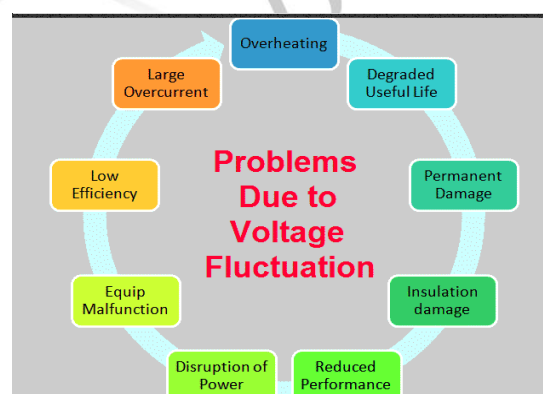

**Fig: Diagram of Problem Identification**

The servo controlled voltage stabilizer is designed and manufactured as per specification by the skilled person(engineer). It is required that the voltage limit should be restricted to 4 percentage according to indian electricity act. It is a reliable product for stable supply.

As the load increases which is connected to the distribution transformer, the voltage starts to fluctuate and it becomes very difficult for the operator to maintain the stable voltage at the output within the updated value. So, because of this fluctuation it became necessary to use servo controlled voltage stabilizer to each and every instrument for almost every instrument.

The execution of any electrical gear is ideal at its appraised voltage. Both over voltage and under voltage produce harmful effects. Under voltage generally reduces efficiency of the instrument whereas over voltage shortens the life of the instrument. So, even domestic appliances like TV Sets, Refrigerators, Computers and other expensive equipment have a need for stabilizer before connecting to the power supply.

**Construction and working of Servo Voltage Stabilizer**

**Servo Based Voltage Stabilizer**

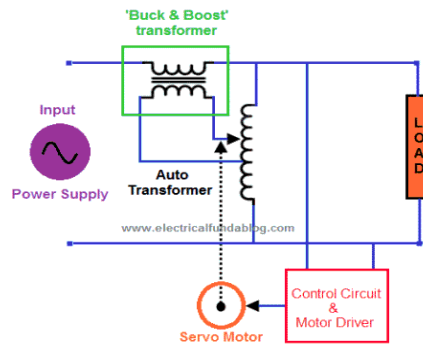

**Fig: Circuit Diagram of Servo Based Voltage Stabilizer**

The electronic circuit board carries out the comparison of the yield voltage with the reference voltage source. As soon as it detects any rise or fall in the input supply beyond the reference value, it starts operating the motor which further moves the arm on the auto-transformer. As the arm of on the autotransformer moves, the input voltage to the essential coil of buck and boost transformer will alter to the specified voltage yield. The servo engine will keep pivoting till the distinction between the reference voltage and stabilizer yield gets to be zero. This total prepared happens in millisecond. Today's servo based voltage stabilizers come with chip based control circuitry to supply brilliantly control to clients.

**Front Panel Diagram:**

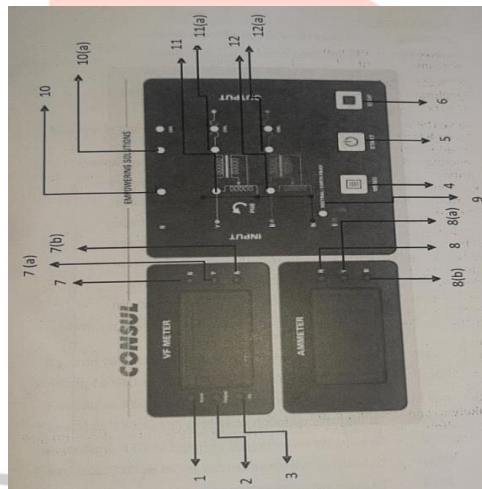

**Specification and Diagram**

VF Meter -To view the voltage at each phase

AMMETER -To view the current at each phase

- 1 - INPUT -To show the input voltage
- 2 - OUTPUT - To show the output voltage
- 3 - HZ -To show the Frequency
- 4 - Menu-To view the all the displays which is showed in VF Meter and AMMETER
- 5 - START- To switch on the output contactor
- 6 - STOP-To switch off or reset the system
- 7 - PHASE R-To show the phase R voltage
- 7(a) - PHASE Y--To show the phase Y voltage
- 7(b) - PHASE B--To show the phase B voltage
- 8 - PHASE R- To show the phase R current
- 8(a) - PHASE Y--To show the phase Y Current
- 8(b) - PHASE B--To show the phase B Current
- 9 -NEUTRAL/EARTH FAULT- To indicate neutral fault condition
- 10 -To identify whether input is ON /OFF at phase R
- 10(a) -To identify whether output is ON /OFF at phase R
- 11 -To identify whether input is ON /OFF at phase Y
- 11(a) -To identify whether output is ON /OFF at phase Y

- 12 -To identify whether input is ON /OFF at phase B
- 12(a) -To identify whether output is ON /OFF at phase B
- PHR -To indicate phase reversal
- OVL -To indicate overload condition at each phase

### Application

These stabilizers are not as it were for domestic utilize but can be valuable in numerous places like healing centers ,refineries, fabricating units, cold capacity, nourishment preparing units ,etc Another applications are as follows,

1. Printing machines
2. Packaging machines
3. plants/Factories
4. Textile machines
5. CNC machines
6. Medical equipment

### Conclusion And Future Scope

The paper introduces the servo voltage stabilizer. So we are able to conclude that the stabilizer could be a must for each house within the summer and blustery seasons as that's the time for control variances. These stabilizers can direct the control supply and give clean energy. It anticipates over-burden when brief circuit as well. It makes your electrical apparatuses more solid and mix strides life by anticipating arm due to variance. It saves energy and makes the appliances more efficient and increase in production. It can improve safety as well as protection of your appliances. Nowadays we are using many kinds of Electronic equipment for domestic and industrial use such as Heavy machinery in Factories and light backup systems in Factory Offices. If about the domestic use like TV, Fridge, AC these all equipment run with help of Electronic Power and we need A Equipment who can control the voltage fluctuation to save our product.

### References

- [1] Design of Fuzzy Logic Controller for Customized Servo Voltage Stabilizer, by P. Eswaran, Mahasamudram Nishanth, IEEE Paper.
- [2] Design of Transformers for 60 kVA Automatic Voltage Stabilizer by Ms. Yin Yin Pyone IEEE Paper.
- [3] Multiprocessor Communication System for Three Phase Servo Stabilizer by Ms. Surekha R. Patil and Mr. Amol B. Jagdale, IEEE Paper.
- [4] Solid State Stabilizer by Mr. U. M. Rao, Ms. Vijaya, Mr. N. Prasad, Ms. Krishna Shree, IEEE paper
- [5] Electrical Tree Inhibition by Voltage Stabilizers, by M. Jarvid1, A. Johansson2, V. Englund3, S. Gubanski2, M. R. Anderson.
- [6] Electronic Tap-Changing Stabilizers for Medium-Voltage Lines Optimum Balanced Circuit, by Joaquín Vaquero Lopez , Salvador Martínez Garcia , Juan Carlos Campo Rodriguez , Rubén Vela Garcia .
- [7] Power System Voltage Stabilizer Using LC Resonance Circuit With Superconducting Coil and Capacitor, by Shinobu Kawashima, Takeshi Ishigohka, Akira Ninomiya, Mitsuho Furuse.
- [8] Study on voltage compensation method of voltage stabilizer of voltage dependent load on ship by, Heli Xu, Lan Gao, Liang Sun.