

Height Adjustable Speed Breaker and U-Turn Indicator

¹Shivaprasad K, ²Chushika Bose, ³Harshitha Deepanjali

¹Assistant Professor

Department of Electronics and Communication,
MIT Mysore, India

Abstract— In developing nations there is a rapid increase in number of vehicles and due to this the number of accidents are increasing. This paper aims to reducing the number of accidents and decreasing the consumption of the fuel due to road bumps. The primary objective is to detecting of the speed of the vehicle whether, the vehicle is above or below the speed limit. Then an automatic speed bump is raised according to the speed of the vehicle. So it can help in avoiding the major road accidents and provides a comfort for people who are driving vehicle within the speed limit. U-turn indicators in roads in present are only the sign board. Here additional indications are added along with the present ones in order to avoid major road accidents while vehicle crossing the road median. This work is carried out using Arduino Uno and programming is done using Arduino IDE software. The automatic raising and falling of road hump based on the speed of the vehicle is implemented.

Index Terms—Speed Bump, Arduino, U-turn indicator, servo motor, LDR.

I. INTRODUCTION

Rash driving is the cause of many road accidents all over the world. Road bumps play a crucial role and significantly contribute to the overall road safety objective through the prevention of accidents that lead to deaths of pedestrians and damage of vehicles. The speed humps are used for discouraging vehicle drivers from driving excessive speed. These are typically comprised of concrete or solid humps that form a transverse ridge in the road and are generally above the road surface. The vehicles while passing over the hump undergo a jolt, hence the drivers are discouraged for traveling at high speed. For vehicles which are within the speed limit unnecessary fuel consumption may occur due to gear changes during the hump [4]. So the speed hump are may require only when the vehicle is above the speed limit.

I.1 HEIGHT ADJUSTABLE SPEED BREAKER

This paper presents an automatic height adjustable speed humps, which are designed to get activated only if vehicles are travelling above a certain speed and vehicles within the speed limit will not experience the discomfort of the speed bump. Since speed bumps are not experienced for vehicles with in the speed limit the changing of gear of vehicle is not necessary and hence fuel consumption of vehicles due to road bumps may reduce.

I.2 U-TURN INDICATOR

U-turn indications are only sign board in present trend. This paper indicates the fast moving vehicle on the main road to slow down when another vehicle which is taking a U-turn/crossing the road median at a distance of 100/150 meters ahead.

II. METHODOLOGY

Height Adjustable Speed Breaker

The Block diagram of height adjustable speed breaker is shown in Figure 1. The block diagram of Height adjustable speed breaker consists of four major blocks IR sensors, Arduino Uno, Servo motor, and LCD Display. Two IR sensors are used to detect the speed of the moving vehicle and the detected signals are sent to the Arduino board. The signals from the IR sensor are used in Arduino to compute the speed of the vehicle on road and compare the vehicle speed with the limited speed and send signal to servo motor. If the vehicle speed is higher than the limited speed the servo motor raises the hump else it remains in the regular position. Based on the speed of vehicle the presence or absence of hump is displayed on LCD to indicate to driver about hump. The working flow chart of the height adjustable speed breaker is shown below in Figure 2.

Initially when the circuit is powered, the position of the servo is at zero degree which makes the hump flat and “DRIVE SAFE” is displayed on the LCD.

Two IR sensors are placed and the distance between them is constant. When the vehicle passes in front of the first sensor the start time is obtained and when the vehicle passes in front of second sensor the stop time is obtained, using this time is calculated and the Arduino computes the speed of the vehicle using the formula $\text{speed} = \text{distance} / \text{time}$. Based on the speed calculated there are two cases.

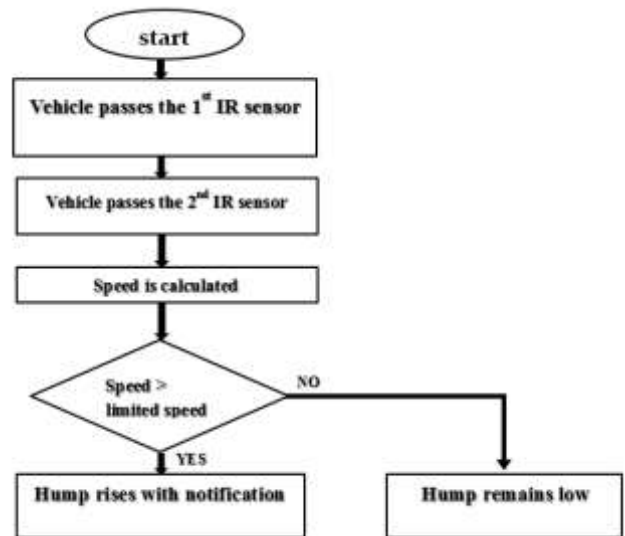
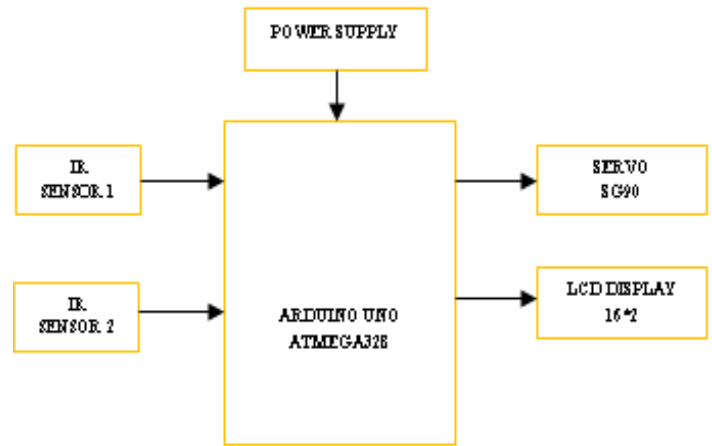

Fig -1: Height adjustable speed breaker

Fig -2: Flow chart of height adjustable speed breaker

CASE 1: If the speed of the vehicle is less than the limited speed, the hump is made flat by making an angle of the servo 0 degree and “DRIVE SAFE” is displayed on the LCD.

CASE 2: If the speed of the vehicle is greater than the limited speed, the hump is raised by making the angle of servo 45 degree and “HUMP AHEAD” is displayed on the LCD.

U-Turn Indicator

The Block diagram of U-Turn Indicator is shown in Figure 3. The Block diagram of U-turn indicator consists of Laser Beam, LDR, LED Indicator, and Buzzer. Laser beam and LDR circuit is used to detect whether any vehicle is taking a U-turn at road median. Buzzer and LCD display are used for indication to vehicles moving from opposite to get slow down since another vehicle which is taking a U-turn /crossing the road median. The circuit diagram of U-turn indicator is shown in Figure4.

The working flow chart of the height adjustable speed breaker is shown below in Figure 5. There are two cases in this.

CASE1: In the presence of light i.e. no vehicle is crossing road median, the LDR will offer low resistance and the supplied voltage will flow directly from VCC to GROUND and the transistor will be in switch off condition hence the buzzer and led will be off without any indication.

CASE2: In the absence of light i.e. vehicle is crossing road median by braking laser beam, the resistor will offer high resistance and the supplied voltage will not flow directly from VCC to GROUND and the transistor will be in switch on condition hence the buzzer and led will be ON which serves as indications.

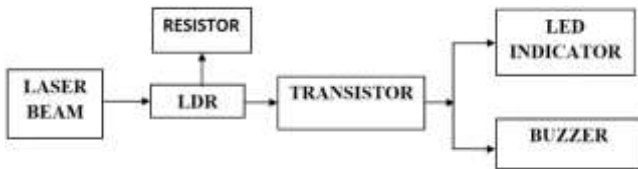

Fig -3: Block Diagram of U-Turn Indicator

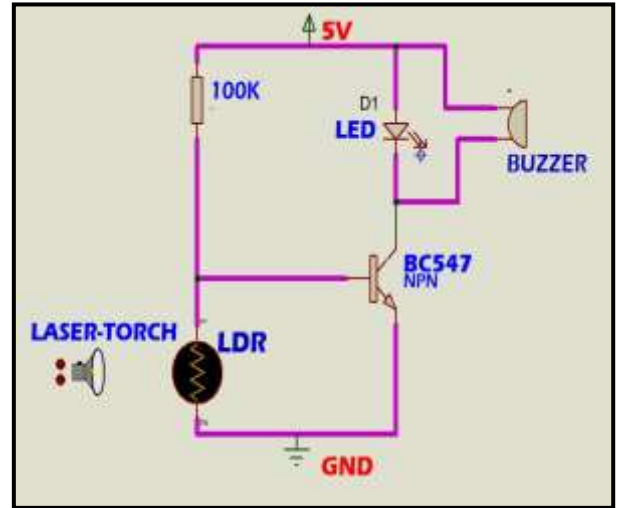

Fig -4: Circuit Diagram of U-Turn Indicator

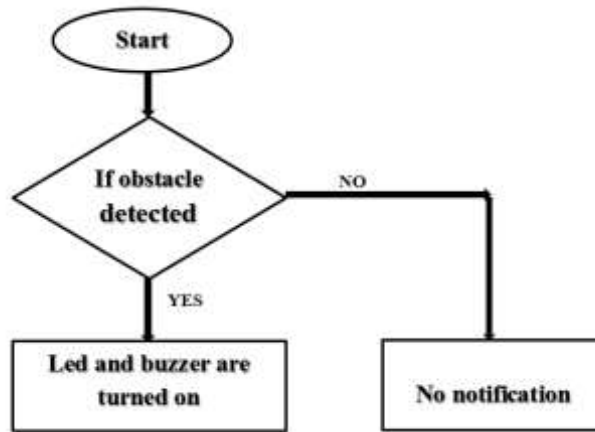

Fig -5: Flow chart of U-Turn Indicator

III. RESULTS

When the speed of the vehicle is within the speed limit the road hump will not be raised and LCD will display “Drive Safe” message as shown in Figure 6 and Figure 7.



Fig -6: Drive Safe displayed on LCD



Fig -7: Absence of hump

If the vehicle speed is above the speed limit the road hump is raised and “Hump Ahead” message will be displayed on LCD. The snapshot of working model is shown in Figure 8 and Figure 9.



Fig -8: Hump ahead displayed on LCD



Fig -9: Hump raised

In the U-turn indicator, when the vehicle crossing the road median (or taking U-turn or obstacle detected) buzzer and LED will be ON, which serve as indication, else buzzer and LED will be in switch off. The snap shot of working model is shown in Figure 10 and Figure 11.

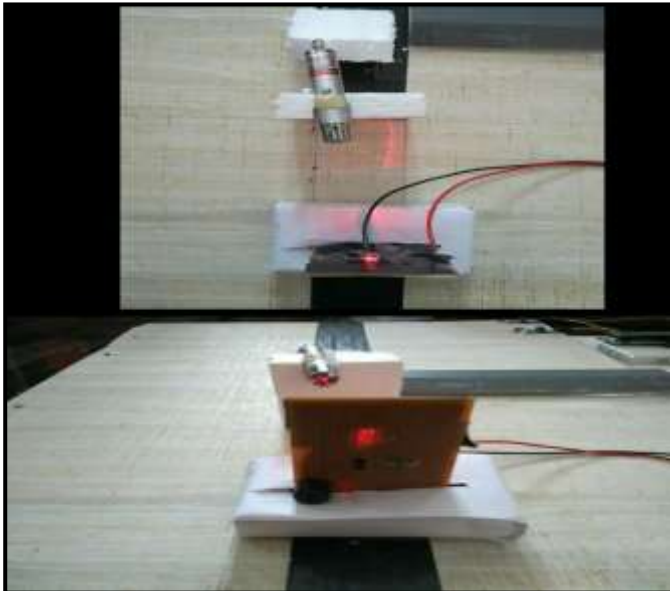

Fig -10: Absence of vehicle

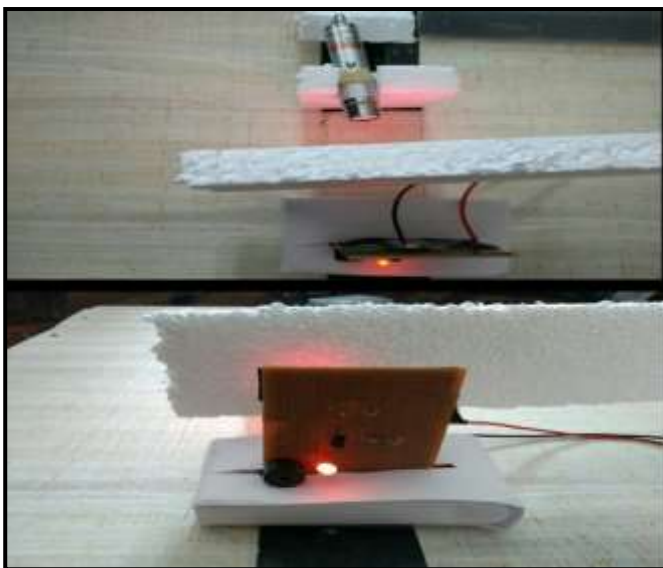

Fig -11: Presence of vehicle

IV. CONCLUSIONS

Raising and falling of Hump based on the speed of the vehicle is implemented. This has been developed to avoid road accidents due to over speeding of the vehicles. This kind of system may reduce fuel consumption of vehicles which are traveling within the speed limit.

The U-turn indicator is implemented. This system avoids road accidents while vehicles are crossing road median.

REFERENCES

- [1] Praveen Kumar and Monika Jain. "Detection of Over Speeding Vehicles on Highway", In Research Article, April 2012.
- [2] Michael L Bond. "Speed Sensitive automatic speed bump" In US (patent), June 2001.
- [3] Stefan Chew. "Electronically Control Height Adjustable Speed Bump", In Kuala Lumpur Malaysia, June 2015.
- [4] Are speed bumps hurting the environment, Gofer team, 2016(<https://www.gofar.co/blog/gofar-blog-read-us>)
- [5] HMA Chew, JY Chew "Height adjustable speed bump", - US Patent. (<https://www.google.com/patents/EP2534305A2?cl=en>)
- [6] Michael L. Bond, "Speed sensitive automatic speed bump" (<https://www.google.co.in/patents/US6457900>)