

Digital Art Using Flex Sensor Based on IOT

Sign Language Conversion

¹Neha Rajput, ²Mrs Neetu Sikarwar

¹Student (M.Tech), ²Professor,

¹Digital Communication, Institute of Engineering, Jiwaji University, Gwalior, Madhya Pradesh, India

Abstract - This work help to people who are suffering from deaf and dumb. The major concern of this paper is to connect them with real world with great esteem. It is based on Human Computer Interaction were the patient is connected to the real world by understanding their sign language into a normal communication. Here hand is considered to be one of the most important parts of our body which is being most frequently used for the interaction in this digital world. Initially the hand glove system is helped in virtual reality in gaming and other aspects. An individual can get connected to the real world people and access their needs effectively.

Keywords - IOT, Sign Language, Flex Sensor.

A. INTRODUCTION

India is second largest populated country in the world. There are lots of people who are suffering from deaf and dumb. This proposal helps them to communicate with normal people by understanding their sign language into normal one or the world with the help of internet of things. This proposed system helps in effective way of disabled people who is often need of help. This system recognises their gesture movement from their hands and relates it through the database and matches their needs which displays in a LCD or computer over internet to their responsible person. This system with Internet of Things helps in receiving the message over internet irrespective to the distance, it enables worldwide connection. This system makes them more interactive than struggling to convey their views or seeking help from the respective ones. Also helps in huge manner that destroy the gap in next generation of people and build a bridge between the disabled people and normal a normal one.

B. OBJECTIVES

1. Helping speech challenged individuals communicate with others without the help of translators
2. To make the device completely portable.
3. To make this technology available to everyone.

C. METHODOLOGY

The proposed framework is a pair of gloves integrated with different sensors which can convert Indian Sign Language to speech with the help of a smart phone to empower speech challenged individuals.

D. HARDWARE USED

1. ARDUINO UNO

The Microcontroller Development Board is based on the Arduino Mega ATmega1280 we used. It has 54 digital input / output pins (14 of which can use 14 PWM outputs), 16 analog inputs, 4 UARTs (hardware serial ports), 16 MHz crystal oscillator, one USB connection, a power jack, an ICSP header, and reset button. It has everything necessary to support the microcontroller. It can be powered by connecting to a computer with a USB cable or AC-to-DC adapter. Mega is compatible with most shells made for Arduino. It is the operating voltage 5V, input voltage 7-12V, input voltage limit 6-20V, DC model 40 mA and 3.3V pin 50 mA, flash memory 128 KB boot loader, SRAM 8KB, EEPROM 4 KB and clock speed 16 MHz .



2. FLEX SENSOR



One of the most important components used on our device is the Flex Sensor. The angle of angle from the curve takes up the measurement when it bends. It is commonly used in areas such as robotics, gaming (virtual motion), medical devices, computer particulars, musical instruments, physical therapy, simple construction, and la profile. It has two types of shapes. One in 2.2 inches and the other is 4.5 inches. It has a temperature range of -35°C to $+80^{\circ}\text{C}$. Flat resistance is about 25K ohm and resistant tolerance is about 30%. It is bend resistance range from 45K to 125K ohm (depending on the bend radius). The life cycle of these sensors is more than 1 million.

3. FORCE SENSOR RESISTOR

In our project, we have used the FSR 400 Series power sensor. This strong polymer thick film (PTF) on the surface of the compound will have a decrease in resistance as the power is increased. This energy sensitivity is optimized for the human touch control of electronic devices such as electronic electronics, robotics applications, industrial and medical systems. It has six different models and we have used the FSR @ 4005mm circle x 38mm. Force resolution is continuous, Force Resolution is continuous, Force repetitive $\pm 2\%$, Non-Active Resistance 10MOms, Hysteresis + 10% Average (less than $RF + - RF -$) / $RF +$, Rear Time Less than 3 microseconds.



E. PROPOSED SYSTEM

1. BLOCK DIAGRAM

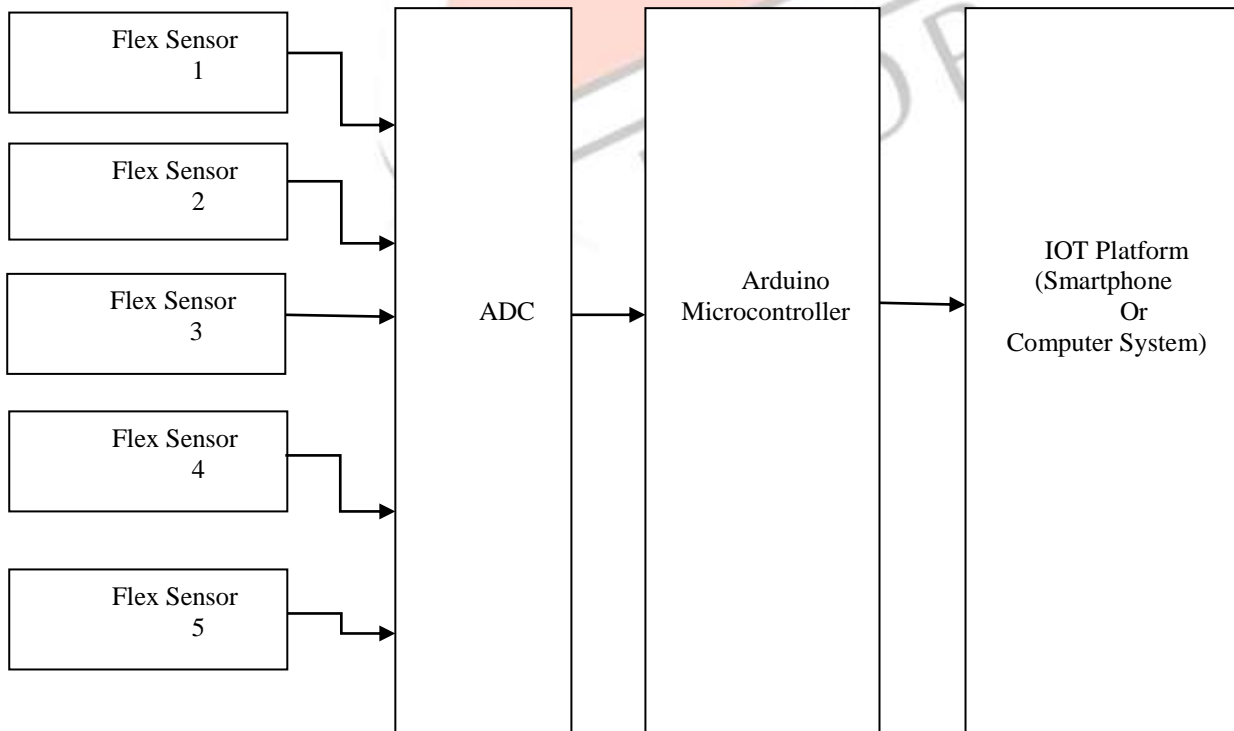

2. FLEX READINGS

S. No	Degrees	Flex Sensor1 Resistance	Flex Sensor2 Resistance	Flex Sensor3 Resistance	Flex Sensor4 Resistance	Flex Sensor5 Resistance
1.	0 Degree	37621	37590	37680	37657	37509
2.	3 Degree	39272	39299	39282	39261	39293
3.	10 Degree	42820	42827	42839	42796	42841
4.	25 Degree	50865	50867	50879	50855	50835
5.	50 Degree	71018	71020	71016	71041	71020
6.	75 Degree	80375	80355	80375	80360	80362
7.	85 Degree	82774	82771	82759	82776	82787
8.	100 Degree	94999	94986	94982	94976	94971

F. ADVANTAGES

- 1) Any complications in its user interface would inhibit the glove's use in everyday life. The user should be able to begin translation without much difficulty or delusory.
- 2) Not financial aid is available for assistive devices. This device should be accessible by the average person by practical and Affordable means.

G. APPLICATIONS

It can be used for computer gaming. It is loaded with touch sensors on the thumb, the fingers and the palm. It allows the wearer to forego using the keyboard. Another application can be in the field of fire extinguishing by fire extinguishers in a situation where members of a team can't even see each other; these gloves will be able to transmit signals via simple hand gestures. The gloves have symbols on them that light up according to the signal received.

CONCLUSION

Our proposed system supports real time communication which makes it more efficient. On the other hand, it also Supports wide range of languages .It is used for short as well as long range communication. Thus our model tries to reduce the difficulties in communication faced by deaf people.

ACKNOWLEDGMENT

I wish to express my profound gratitude and indebtedness to Neetu Sikarwar, Professor, Department of Electronics & communication Engineering, and Institute of Engineering, Jiwaji University, Gwalior who gave me the golden opportunity to do this wonderful project on this topic. I find words in adequate to thank her for his encouragement and valuable suggestions during the course of this work.

REFERENCES

- [1] Rohit Rastogi, Shashank Mittal, Sajan Agarwal, "A novel approach for communication among Blind, Deaf and Dumb people", Computing for Sustainable Global Development (INDIACom), 2015 2nd International Conference,11-13 March 2015.
- [2] Pushpanjali Kumari, Pratibha Goel, S. R. N. Reddy,"PiCam: IoT Based Wireless Alert System for Deaf and Hard of Hearing" ,Advanced Computing and Communications (ADCOM), 2015 International Conference,18-20 Sept. 2015.
- [3] Veronica Lopez-Ludena, Ruben San-Segundo, Raquel Martin ,David Sanchez,Adolfo Garcia,"Evaluating a Speech Communication System for Deaf People",Intelligent Human-Machine Systems and Cybernetics (IHMSC),2015 7th International Conference,26-27 Aug. 2015.
- [4] Girija Sankar Dash, Swetalima Rout, Omprakash Singh,"WiBeD2: A communication aid for deaf and dumb",Information Communication and Embedded Systems (ICICES), 2016 International Conference,25-26 Feb. 2016.
- [5] V. Padmanabhn M. Somalatha" Hand gesture recognition and voice conversion system for mute people" International Journal of Scientific & Engineering Research, Volume 5, Issue 5, May-2014 427 ISSN 2229-5518 Praveen kumar S Havalagi, Shruthi Urf Nivedita.
- [6] American Sign Language Translator Glove by Bhargavi Govindarajan and Anand Vignesh Venkataraman <https://www.hackster.io/15387/american-signlanguage- translator-glove-838bd4>.