

Stress Analysis And Performance Evaluation Of Flange Spool Subjected To Pressure

¹Mr.MSSR Ravi Kiran, ²V Srinath Mani Kumar

¹Assistant Professor, ²M. Tech(CAD-CAM)

Department of Mechanical Engineering

Sreenidhi Institute of Science and Technology , Hyderabad-501301, India

Abstract - In the present scenario, the prevention of failure of a component is having a vital role in piping industry. Failure of a single component can cease the entire functionality of the system. So the prevention of failure is significant to satisfy the customer needs not only aesthetic but also functionality, reliability and utility of the system. With the advancement of new technologies, finding out the failures and giving a pertinent solution is possible. Value engineered component is an added advantage to the industry in all aspects. A flange spool is a basic type of dismantling joint that connect long pipes with flanges at the ends so that they can be bolted to another pipe with matching flange. The flange joint involves interaction between bolts, flange and gasket and it is the most essential part of Pressure vessel, Condenser, Heat exchanger and Storage tank. This flange joint aims at preventing fluid leakage and maintaining the structural integrity of the joint. The objective of this paper is to design and analyze a flange spool which is used to carry and transport processed fluid and gas. This work deals with the replacement of molybdenum steel material flange spool with a silicon-manganese flange spool. The modeling was done using CATIA software as per API standards. The flange spool is modeled and simulated using ANSYS 15 Software. The design optimization also showed significant potential improvement in the performance of flange spool. In the present work finite element analysis procedure is used in ANSYS simulation to predict the levels of stress and deformation of flange spool under subjected loads .

Index Terms - Flange Spool, CATIA, ANSYS, Finite Element Analysis.

I. INTRODUCTION

A flange spool is a basic type of dismantling joint that connect long pipes with flanges at the ends so that they can be bolted to another pipe with matching flange. The flange joint involves interaction between bolts, flange and gasket and it is the most essential part of Pressure vessel, Condenser, Heat exchanger and Storage tank. The usage of flange spool pipes in different fields ranges from city water distribution networks to sub-sea oil transportation to cryogenic applications. This flange joint aims at preventing fluid leakage and maintaining the structural integrity of the joint. An imprecise design can lead to major leakage, affect the system performance and can be hazardous for operators.

The overall objective of this paper is to design and analyze a flange spool which is used to carry and transport processed fluid and gas. This work deals with the replacement of molybdenum steel material flange spool with a silicon-manganese flange spool. In the present work an attempt has been made to estimate the deformation and stresses under subjected loads using FEA.

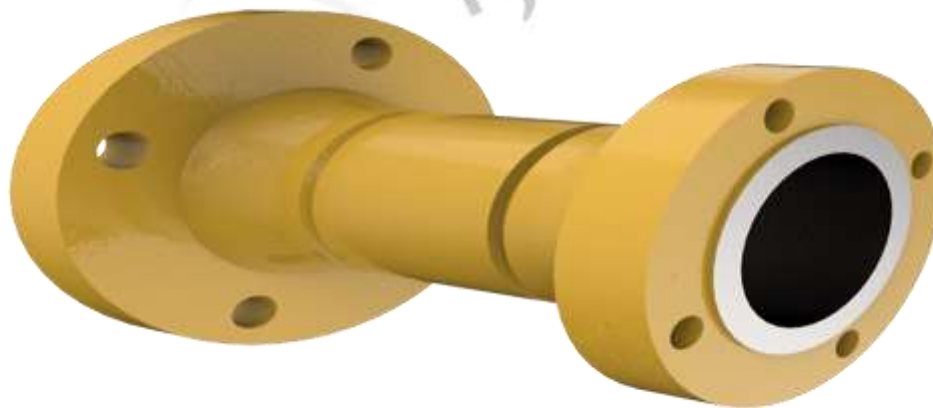

Fig 1 : Flange Spool

II. MATERIALS & METHODS

2.1 Modeling of Companion Flange

The 3D Model of flange spool is done using CREO as per API standards.

The dimensions of the flange spool are as follows :

FLANGE INNER DIAMETER	3.125"	3.063"
FLANGE OUTER DIAMETER	10.50"	10.625"
FLANGE THICKNESS	2.19"	2.30"
BOLT CIRCLE DIAMETER	8.00"	8.50"
No of BOLT HOLES	8	8
BOLT SIZE	1.25"	1.125"
HUB OUTER DIAMETER	5.25"	5.59"

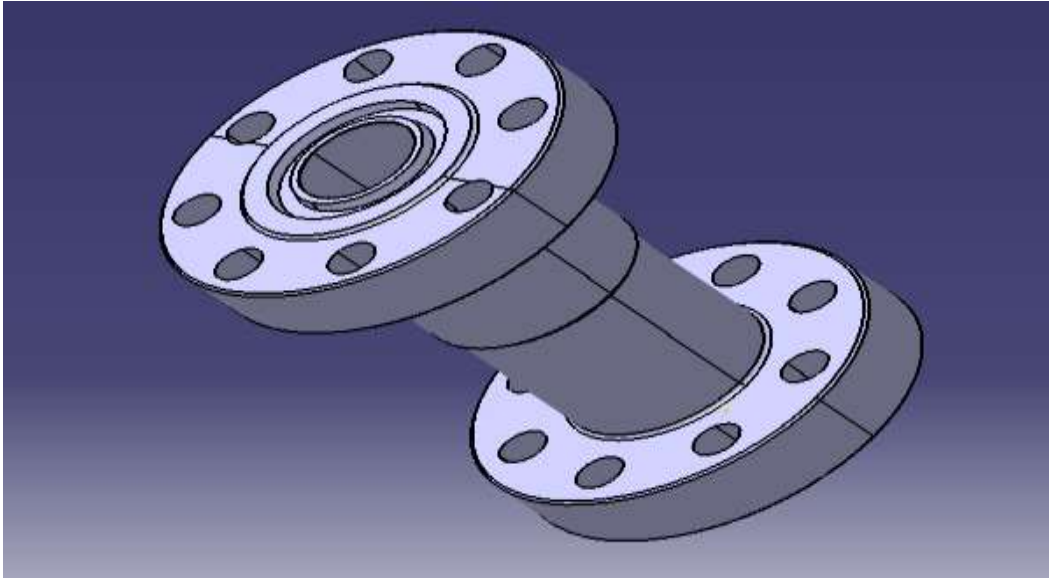

Fig 2 : 3D Model of Flange Spool

In this study the mechanical properties of the flange spool are treated to be Isotropic, homogenous and linear elastic. The AISI 4130 material is selected for flange spool which is being compared with AISI 9310. The Table shows the properties of the AISI 4130, 4118, 4320 and 9310.

Mechanical Properties of materials

	AISI 4130	AISI 4118	AISI 4320	AISI 9310
DENSITY	7850 Kg/m ³	7850 Kg/m ³	7850 Kg/m ³	7850 Kg/m ³
YOUNG'S MODULUS	200 Gpa	200 Gpa	201 Gpa	205 Gpa
POISSONS RATIO	0.29	0.29	0.29	0.29
YEILD STRENGTH	435 Mpa	365 Mpa	425 Mpa	986 Mpa
TENSILE STRENGTH	670 Mpa	517 Mpa	580 Mpa	1234 Mpa

2.2 Finite Element Model

For the present study ANSYS Workbench 15.0 is used. The Flange spool model is imported in to Workbench. A mesh analysis is done on the FEA mode of flange, to ensure the optimum mesh size of FEA model for proper convergence and exact numerical results. The model is meshed using tetrahedral elements.

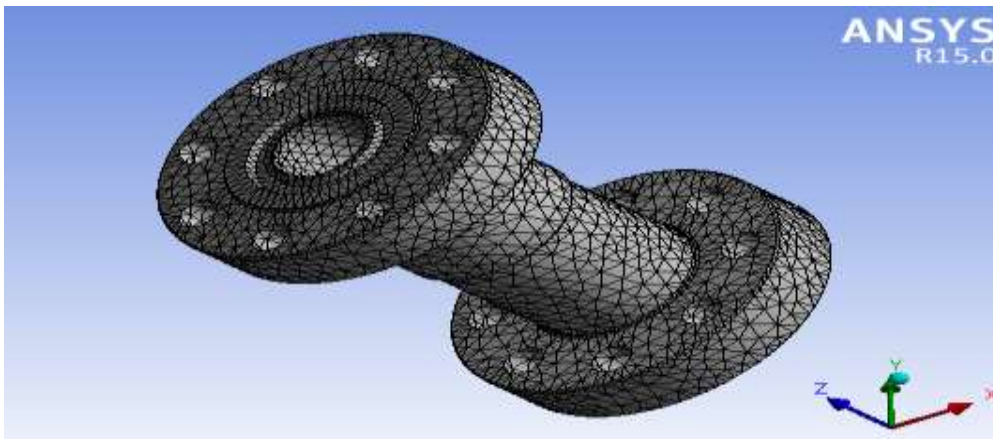

Fig 3: Meshed Flange Spool

2.3 Boundary conditions

The boundary conditions for the flange spool are fixed support and pressure. Fixed support is in the bolt holes of the spool. And pressure of 32.48 Mpa is applied on the inside diameter of the spool and the chamfer of the neck. The movements in Z-axis directions of flange are given. The other movements $U_y = U_x = 0$ of flange are zero, while the boundary conditions of the flange are fixed. The movements in all the three axes are constrained, $U_x = U_y = U_z = 0$.

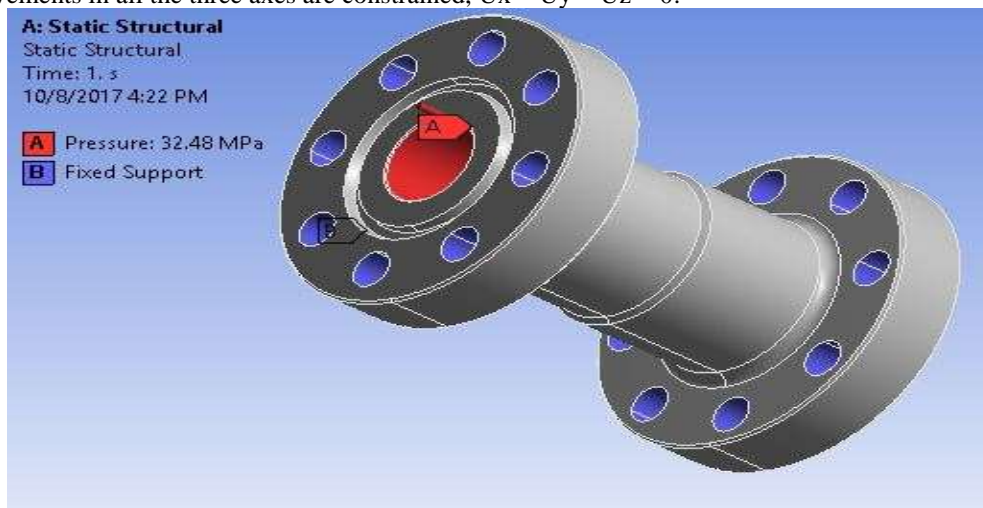

Fig 4: Boundary conditions of Structural Analysis

III. RESULTS

In the present FEA study Total deformation and equivalent stress values are considered for evaluating the results.

3.1 Equivalent Von-mises Stress :

The von-mises stress is used to predict yielding of materials under complex loading from the results of uni-axial tensile tests. A material is said to start yielding when the von-mises stress reaches a value known as yield strength.

When the pressure is applied the maximum stress and minimum stress induced in flange spool are 435.06 Mpa and 0.983 Mpa.

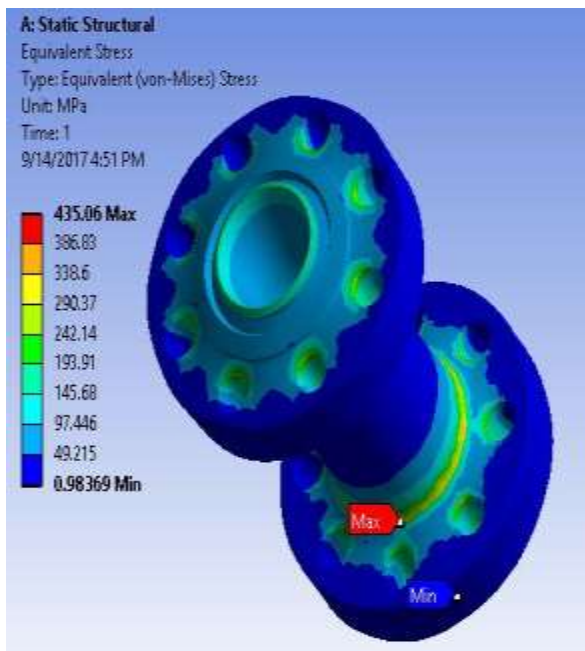

Fig 5: Equivalent Von-misses stress of AISI 4130

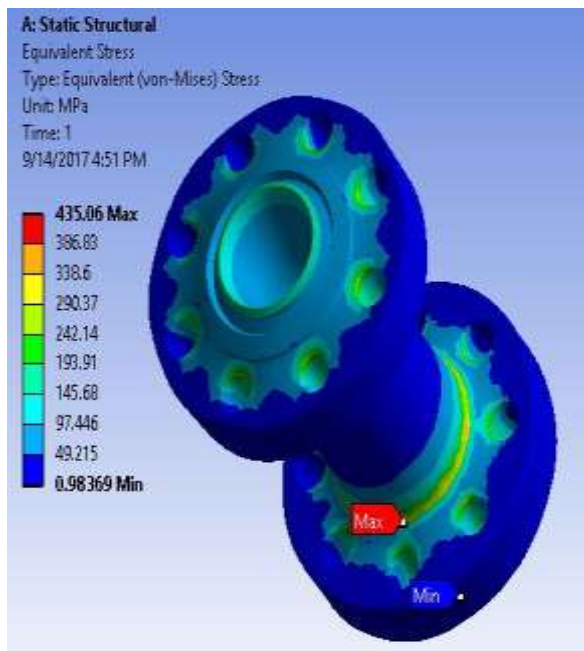

Fig 6: Equivalent Von-misses stress of AISI 4118

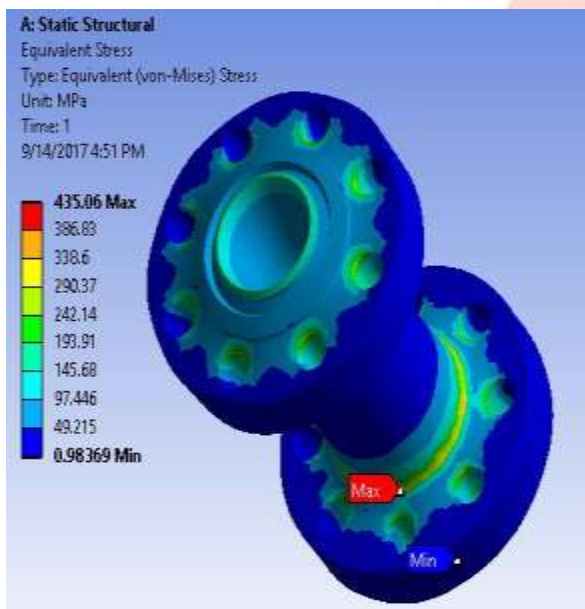

Fig 7: Equivalent Von-misses stress of AISI 4320

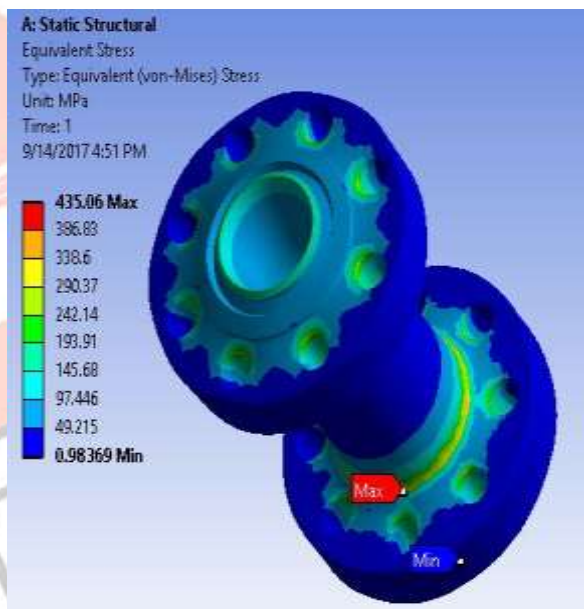

Fig 8: Equivalent Von-misses stress of AISI 9310

3.2 Deformation :

Deformation signify variation in size and shape due to the exerted force. This could be witnessed because of tensile forces(pulling), compressive forces(pushing), torsion or bending(twisting) and shear.

When the pressure is applied the maximum deformation in AISI 4130, AISI 4118, AISI 4320 and AISI 9310 materials flange spool are 0.0748 mm, 0.0748 mm, 0.0730 mm and 0.0696 mm respectively.

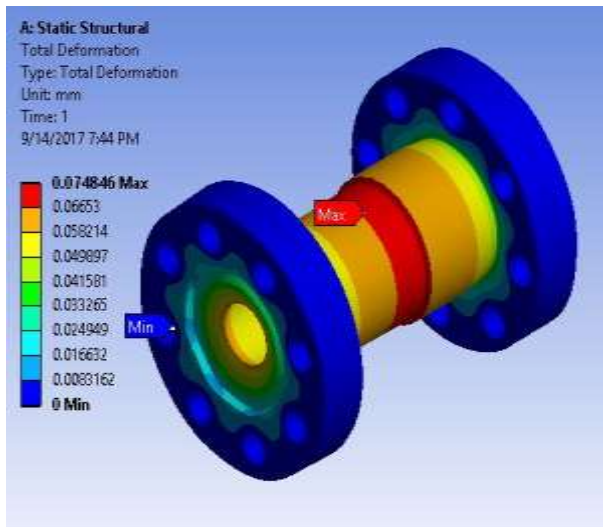

Fig 9: Deformation of AISI 4130

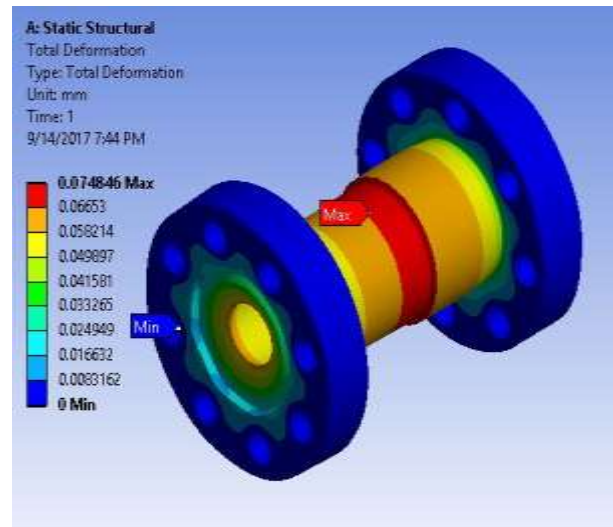

Fig 10: Deformation of AISI 4118

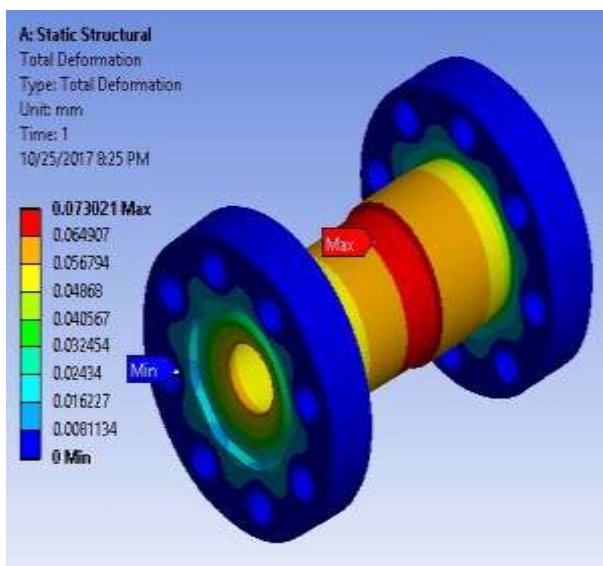

Fig 11: Deformation of AISI 4320

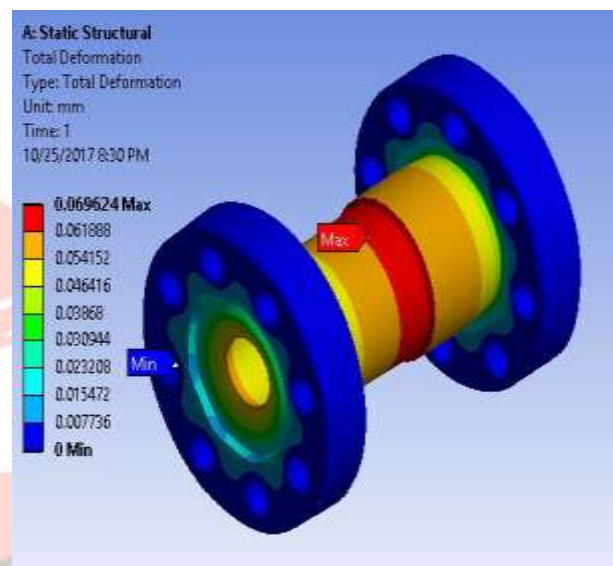

Fig 12: Deformation of AISI 9310

Optimal Design Values Of Flange Spool Static Structural Analysis

	AISI 4130	AISI 4118	AISI 4320	AISI 9310
EQUIVALENT VON-MISES STRESS (max)	435.06 Mpa	435.06 Mpa	435.06 Mpa	435.06 Mpa
YEILD STRENGTH	435 Mpa	365 Mpa	425 Mpa	986 Mpa
DEFORMATION	0.0748 mm	0.0748 mm	0.0737 mm	0.0696 mm

When a higher pressure of 73.61 Mpa is applied on AISI 9310 flange spool.

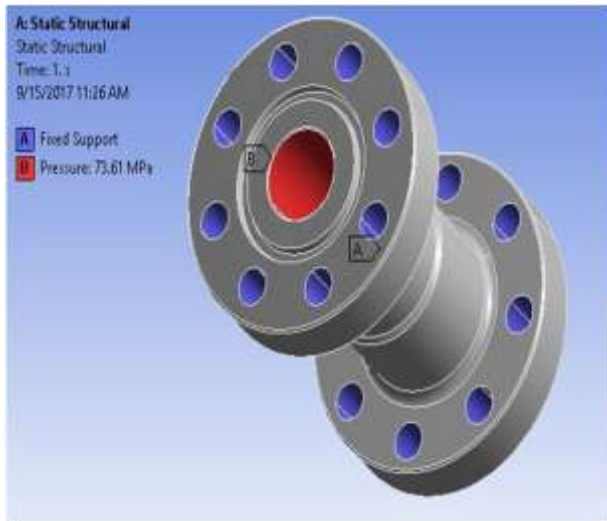

Fig 13: Boundary condition of AISI 9310

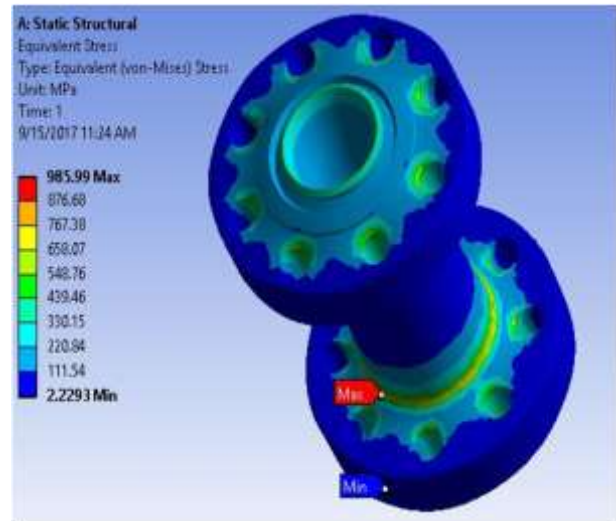

Fig 14: Equivalent Von-misses stress of AISI 9310 with pressure 73.61 Mpa

Comparison Between AISI 4130 and AISI 9310

	AISI 4130 Pressure 32.48 Mpa	AISI 9310 Pressure 73.61 Mpa
EQUIVALENT VON-MISSES STRESS (max)	435.06 Mpa	985.99 Mpa
YEILD STRENGTH	435 Mpa	986 Mpa

3.3 CHEMICAL COMPOSITION

	AISI 4130	AISI 4130
Iron	97.03 – 98.22 %	94 %
Chromium	0.80 – 1.0 %	1.0 – 1.4 %
Manganese	0.40 – 0.60 %	0.45 – 0.65 %
Carbon	0.28 – 0.33 %	0.08 – 0.13 %
Silicon	0.15 – 0.30 %	0.15 – 0.30 %
Molybdenum	0.15 – 0.25 %	0.08 – 0.15 %
Sulfur	0.040 %	0.020 %
Phosphorus	0.035 %	0.025 %
Nickel		3.0 – 3.5 %

IV. CONCLUSION

1. In this project finite element analysis has been carried out on flange spool. Flange spool has tremendous applications in petroleum distillation, power plants, chemical processing, pressure vessels, heat exchangers, storage tanks etc.,
2. CATIA and ANSYS software have been exhaustively used for the structural study of flange spool.
3. When a pressure of 32.48 Mpa is applied on flange spool, the von-misses stress achieved from Ansys structural analysis is in good agreement with the yield strength for AISI 9310 when compared to AISI 4130 and other materials. However AISI 9310 could withstand even more pressure i.e., up to 73.61 Mpa.
4. When a pressure of 32.48 Mpa is applied on flange spool, the maximum deformation achieved is less for AISI 9310 material flange spool when compared to all other materials flange spools.
5. From material chemical composition comparison between AISI 4130 and AISI 9310, since chromium content is more in AISI 9310 and so it is more corrosion resistant than AISI 4130.
6. Thus the results obtained from finite element static structural analysis and comparison of material chemical composition shows that AISI 9310 material flange spool is better and safe compared to AISI 4130 material flange spool.

V. REFERENCES

[1] Abid M, Chattha J. A, Khan K. A, “Finite Element Analysis of a Gasketed Flange Joint Under Combined Internal Pressure and Thermal Transient Loading”, Proceedings of ASME PVP2007/Creep 8 Conference, 2007.
 [2] Power D finite element analysis techniques, MPhil Thesis, Strathclyde University, Glasgow, UK. 1997., A study of conventional and unconventional flanged pipe joint styles using non linear finite element analysis.

- [3] Sawa T and Shimizu A. A stress analysis of pipe flange connections subjected to external bending moments. ASME 2000; 405: 85–94.
- [4] Muhsen Al-Sannaa and Abdulmalik Alghamdi, “Two dimensional finite element analysis for large diameter steel flanges”, 6th Saudi Engineering conference (2002), Vol.5, pp. 397-408.
- [5] Shivaji G. Chavan “Stress Analysis of Flanged Joint Using Finite Element Method” (IJSR), Volume 3 Issue 8, August 2014, ISSN (Online): 2319-7064.
- [6] P. M. Desai, B. C. Pathak, V. A. Patel and P. B. Rana, Design, Analysis and Optimization of Body Flange and Cover Flange Using Finite Element Analysis, International Research Journal of Mechanical Engineering and Technology (IRMET), 4(5), 81-87, 2013.
- [7] Estrada H, and Parsons I.D.1999. “Strength and Leakage Finite Element Analysis of a Fiber Reinforced Plastic Stub Flange Joint.” International Journal of Pressure Vessels and Piping 76: 543-50.
- [8] Flinn, R. A., and Trojan, P. K. 1990. Engineering Materials and Their Apparitions. 4th ed. Boston: Houghton Mifflin Company.
- [9] Nishioka, K., Morita, Y., and Kawashima, H. 1979. “Strength of Integral Pipe Flanges (No. 1 Stress Distribution in Flange and the Criticism of the Conventional Standards).” Bulletin of the JSME 22 (174): 1705-11.
- [10] Modestova R.V, Gudkov V.V, Kasyanchek G.I, Samofalov O.P, Flange joints of vessel and apparatus made of aluminum, Journal of Chemical and Petroleum Engineering, 1985, 21, 12, 572-573.

