

Performance Analysis of Shunt Active Power Filter with Various Switching Signal Generation Techniques

¹ Mr. Shashibhushan R. Shahu,² Mr. Nikhil A. Wanjari

¹ P. G. Student,² Assistant Professor,
Department of Electrical Engineering
S. D. College of Engineering, Selukate Wardha

Abstract— The performance of shunt active power filter (SAPF) is compared for steady state load condition. The SAPF is used for harmonic compensation of single phase ac/dc converter feeding a nonlinear load. The process involves an injection of equal but opposite current to mitigate the distortion current supplied back by nonlinear load to the voltage supply. Thus, the injected current will shape the supply current to a sinusoidal phase with the supply voltage. The techniques which are considered for comparative study are Hysteresis Current Control (HCC) and Sinusoidal Pulse Width Modulation (SPWM) technique. Performance analysis of above two switching signal generation based on percentage (THD) Total Harmonic Distortion, complexity speed of response, switching frequency and delay time in MATLAB. we can analyse the different results on above two methods based on given parameters of SAPF. The percentage THD of supply current reduces as per IEEE519 standard. HCC is simple in implementation over SPWM technique. The speed of response of both controllers is same. The switching frequency of HCC is variable but the SPWM technique operates fixed switching frequency. This is done by injecting equal but opposite current to shape the pulsating supply current to a sinusoidal form and in time phase with the supply voltage. Consequently, it would reduced input current distortion and achieve unity power factor when feeding a nonlinear load.

Index Terms— Shunt Active Power Filter (SAPF), Hysteresis Current Controller (HCC), Voltage Source Inverter (VSI), Hysteresis Band (HB), Synchronous Reference Frame (SRF), Sinusoidal Pulse Width Modulation (SPWM), Total Harmonics Distortion (%THD), Switching Frequency

I. INTRODUCTION

Technological development leads to increase in use of nonlinear loads which leads to deprivation in power quality. Power quality has assumed an increased importance as customers demand better service from electrical supply companies and also it has to compete with other in newly deregulated electricity markets. The power quality assumed to be high when it has constant voltage level and low voltage harmonic distortion and low number of disturbing transients. All these power qualities cannot be achieved easily it is therefore necessary to install extra equipment to mitigate the effects of possible causes of low power quality. One such equipment installed is the shunt active power filter which operates to lower the harmonic current flowing in the AC system. Active power filters are increasingly used to compensate for harmonics and reactive power generated by nonlinear loads which are installed by various utility. These modern devices are becoming widely adopted due to their energy efficient operation these modern electronic equipment generally draws non-sinusoidal currents from the AC supply. The generalization of static converters in industrial activities and by consumers leads to an increase in harmonic injection in the network and also lowers the power factor. The injection of these harmonics causes many problems to the distribution system, such as transformer overheating, resonance problems in the utility, increase losses, malfunction of protective devices such as relays, circuit breakers etc. Several methods of compensation are proposed to improve the power quality and reduced the harmonics in distribution system.

The control approach for a shunt active power filter generates reference current that must be provided by power filter to compensate reactive power and harmonic currents demanded by the load. This involves a set of currents in the phase domain, which will be tracked generating the switching signals applied to electronic converter by means of the appropriate closed loop switching technique such as hysteresis current controller. Recently shunt active power filter operates by high frequency pulse width modulation technique to inject the required non-sinusoidal current requirements of non-linear loads. This is done by injecting equal but opposite current to shape the pulsating supply current to a sinusoidal form and in time phase with the supply voltage. It will reduced input current distortions and achieve unity power factor when feeding a typical non-linear loads.

II. BASIC CONCEPT SHUNT ACTIVE POWER FILTER

The structure of a three-phase shunt APF is mainly made up of a voltage source converter with a large capacitor to maintain the voltage constant at the DC side and three inductors to output the compensation current at the AC side in connection with the utility. In fact, this kind of APF in nature is Boost circuit as the same as the high frequency reversible PWM rectifier, which means the DC voltage level must be higher than the peak-to-peak value of the utility line-to-line voltage so as to control the output current completely. Three IGBT semiconductor switching.

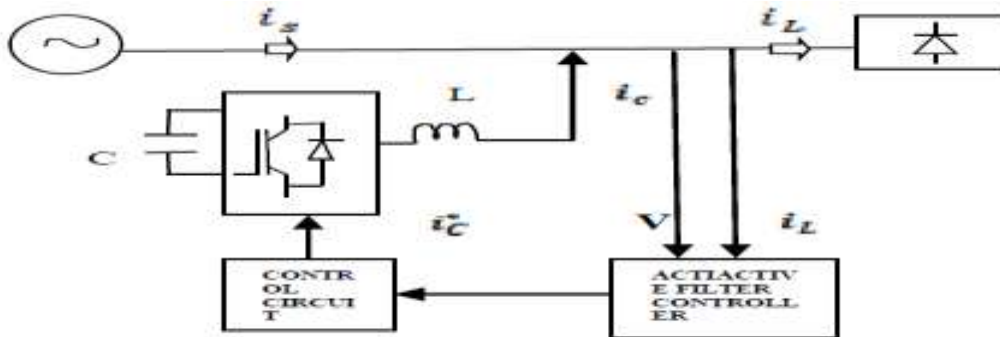

Fig. 1. Basic configuration of a SAPF

III. SWITCHING SIGNAL GENERATION TECHNIQUE

There are different switching signal generation techniques can be implemented in shunt active power filter based on current controller or voltage controller. Current controller can be classified as hysteresis, ramp comparison, Delta modulation, Predictive controllers and Deadbeat control[4][5]. Voltage controllers can be classified as sinusoidal pulse width modulation (SPWM) and space vector pulse width modulation (SVPWM). Hysteresis controllers utilize some type of hysteresis in the comparison of line current to the current references. The ramp comparison controller compares the current errors to a triangle waveform to generate the inverter firing signals. In SPWM, the modulating or the reference wave is the sine wave and the carrier is triangular wave. Space vector modulation utilizes DC bus voltage more efficiently and generates less harmonics in a three phase voltage source inverter. In SVPWM methods, the voltage reference is provided using a revolving reference vector [1][4].

1. Sinusoidal Pulse Width Modulation (SPWM)

This technique is also called as Sine-Triangle Current Regulator. In sinusoidal PWM, the modulating or the reference wave is the sine wave and the carrier is the triangular wave. This control performs a sine-triangle PWM voltage modulation of the power converter using the current error filtered by a proportional-integral (PI) regulator. In each phase there is a linear PI regulator which compares the current reference and the current filter, and consequently generates the command voltage [2]. The sinusoidal PWM voltage control (SPWM) scheme is a linear control. PI controller is used to remove lower order frequency and ripples in the error signal. The block diagram of SPWM is shown in Fig.4. The difference between the reference currents (I_{ca}^* , I_{cb}^* , I_{cc}^*) and compensating currents (I_{ca} , I_{cb} , I_{cc}) are sent to PI controller to generate reference voltage (v_{ra} , v_{rb} , v_{rc}). These voltages are compared with the triangular carrier signals by using limit comparators to generate switching pulses of six IGBTs [7].

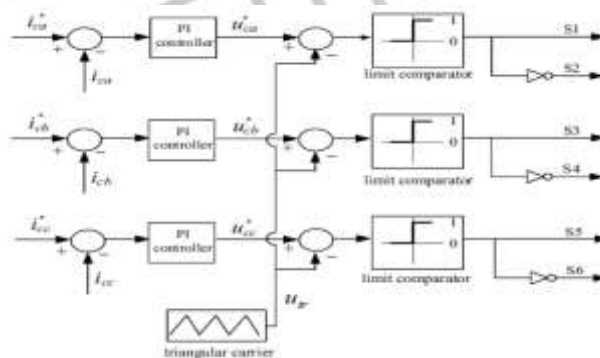

Fig.2 The block diagram of SPWM controller

The principle of the carrier-based PWM current control is illustrated in Fig.2 For example in phase a , if the reference voltage (u_{ca}^*) is over than the triangular carrier voltage (u_{tr}) then the comparator output is 1 ($S1=1$, $S2=0$). If u_{ca}^* is less than u_{tr} then the comparator output is 0 ($S1=0$, $S2=1$). The switching frequency of this technique is constant and it is equal to the frequency of triangular carrier (f_{tr}) signal. This value can be designed by the maximum order of harmonic component considered for elimination [12].

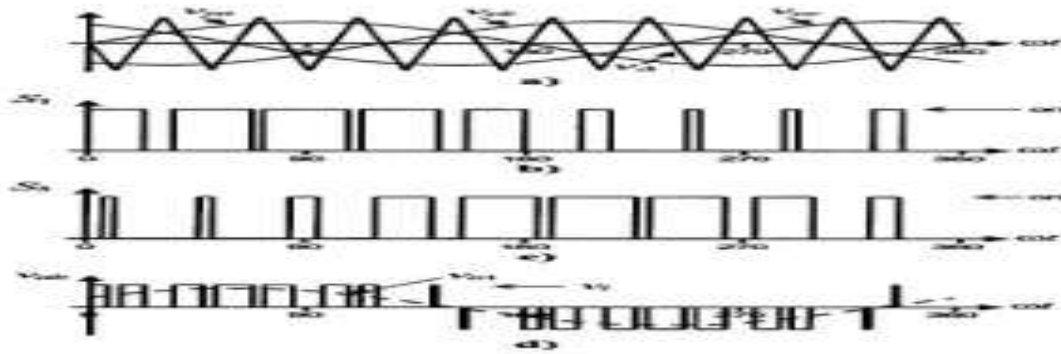

Fig.3 The basic concept of SPMW controller

The sinusoidal PWM is very easy to implement using comparators and integrators for the generation of carrier and switching states. Synchronous Reference Frame (SRF) method of current generation is implemented for reference current generation purpose.

2. Hysteresis Current Controller (HCC)

The basic principal of hysteresis current controller is that the switching signals are generated from the comparison of the current error signal with a fixed hysteresis band. It is a closed loop system which detects the current error and generates the switching pulses of IGBT when the error exceeds an assigned band. The advantages of this technique are high simplicity, good accuracy, outstanding robustness and fast dynamic and automatic current limited characteristics response. This control technique exhibit main disadvantage variable switching frequency of inverter. This is responsible for designing the ripple filter due to the resonance [5].

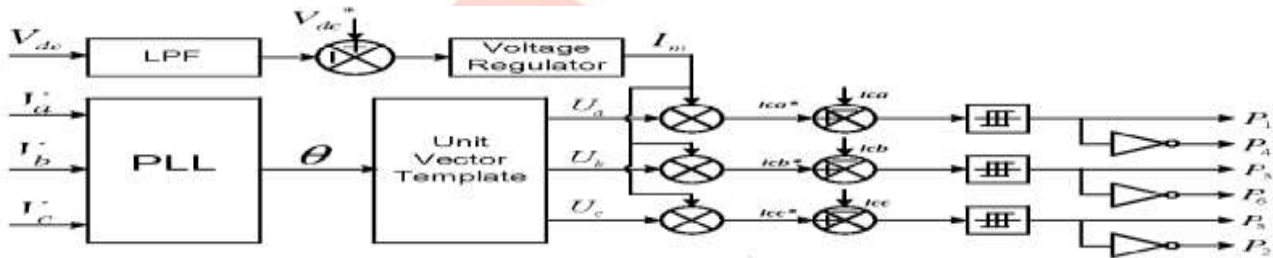

Fig.4 The block diagram of the hysteresis current controller.

The hysteresis controller is used to control the load current and determine the switching signals for inverter gates. The hysteresis current controller technique based upon nonlinear control as shown in Fig.4. The compensating currents (\$i_{ca}\$, \$i_{cb}\$, \$i_{cc}\$) in Fig.2 are compared with the reference currents (\$i_{ca}^*\$, \$i_{cb}^*\$, \$i_{cc}^*\$) by using hysteresis comparator to generate the six switching pulses. These pulses are used to control the IGBTs to turn ON and turn OFF. The basic concept of hysteresis current control is shown in Fig.3

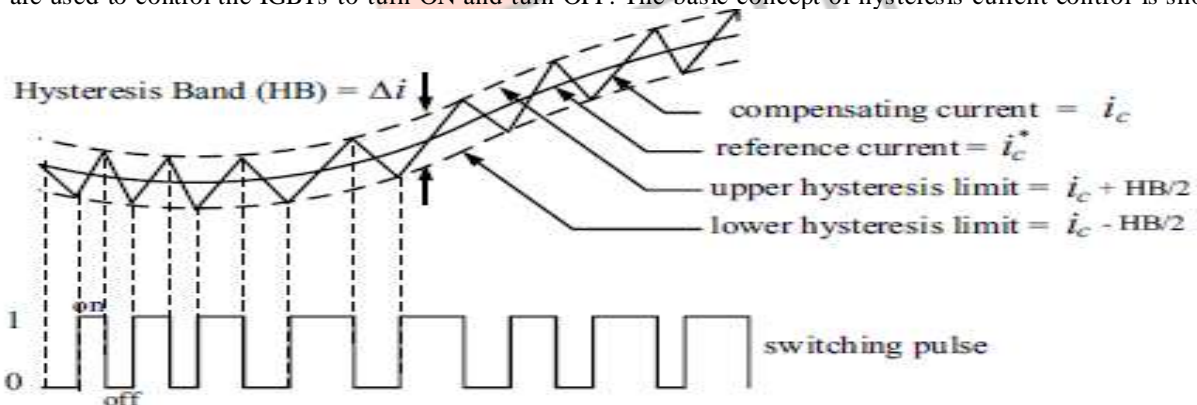

Fig.5 The basic principle of the hysteresis current controller.

From the reference of Fig.5 hysteresis band (HB) is the possible boundary of the compensating current. This current swings between upper and lower hysteresis limits. In hysteresis controller, instantaneous current or error will give switching signal to the gate of IGBT[1]. For example in phase a, if is equal or less than lower hysteresis limit (\$i_{ca}^* - HB/2\$) then the comparator output is 1 (P1 is ON, P4 is OFF). On the other hand if is equal or over than the upper hysteresis limit (\$i_{ca}^* + HB/2\$) then the comparator output is 0 (P4 is ON, P1 is OFF).

The switching frequency of IGBT can be calculated by equation (1). It will depend upon line inductance of active power filter and dc link capacitor voltage configuration.

$$F_{s,max} = 2V_{dc}/9HBL_f \dots \dots (1)$$

IV MODELING IN MATLAB SIMULINK

1.Shunt APF without current controller circuit.

The nonlinear load connected to the three phase supply is simulated and shown in the Fig.6 this system is not having connection of three phase shunt APF.

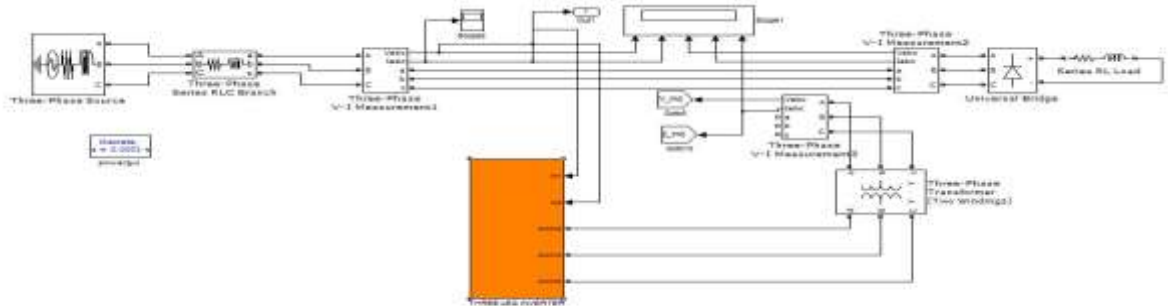

Fig.6 Simulink diagram of nonlinear load without Shunt Active Power Filter (SAPF)

2. Shunt APF with Sinusoidal Pulse Width Modulation (SPWM)

This technique is also called as carrier-based PWM technique, the modulating or reference wave is sine wave and carrier is triangular wave. The Simulink of shunt active power filter with sinusoidal pulse width modulation is shown in Fig.7 where the switching signals for IGBTs of voltage source inverter are obtained by difference between reference voltage and carrier voltage. The reference voltages are generated by PI controller which will act as voltage regulator.

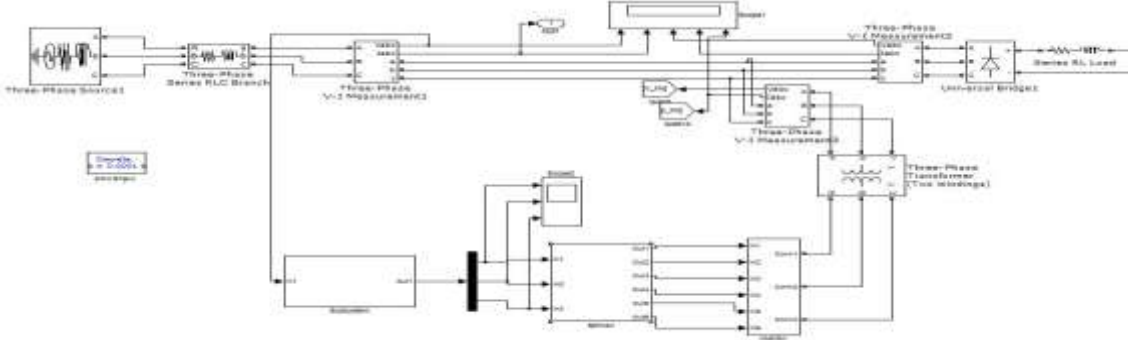

Fig.7 Simulink Diagram of shunt APF with Sinusoidal Pulse Width Modulation

Fig.8 shows the subsystem of sinusoidal pulse width modulation (SPWM) where the reference voltages ($u_{ca}^*, u_{cb}^*, u_{cc}^*$) is compared with (u_{tr}) one by one and from this comparison the switching signals for IGBTs are generated in the three legs of voltage source inverter.

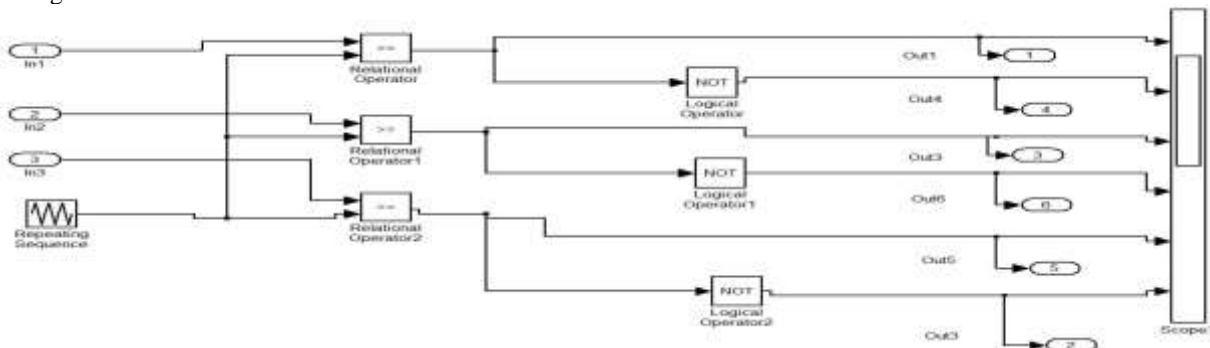

Fig.8 Simulink diagram of Sinusoidal Pulse Width Modulation.

3. Shunt APF with Hysteresis Current Controller (HCC)

Fig.9 shows Simulink model in which the Shunt APF is connected in parallel with nonlinear load which will compensate reactive power and harmonics compensation. This SAPF is simply three phase voltage source inverter, the switching signal of IGBT's are obtained by comparing the reference current and compensating current of active power

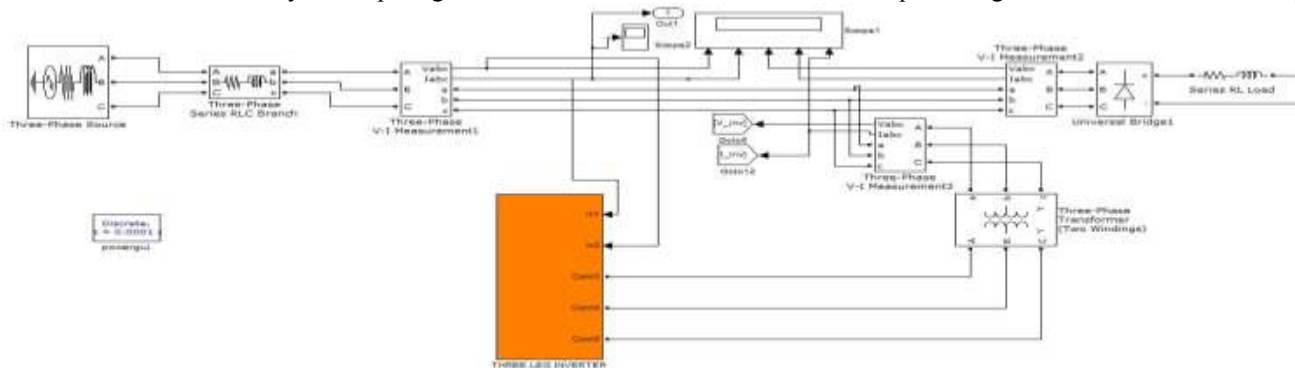

Fig.9 Simulink diagram of Shunt APF with Hysteresis current controller

The Simulink diagram of hysteresis current controller is shown in Fig.10 where the reference current are generated by unit vector template and PI regulator and are compare with compensating current of system which will generate switching signals for six IGBTs in three legs of Inverter.

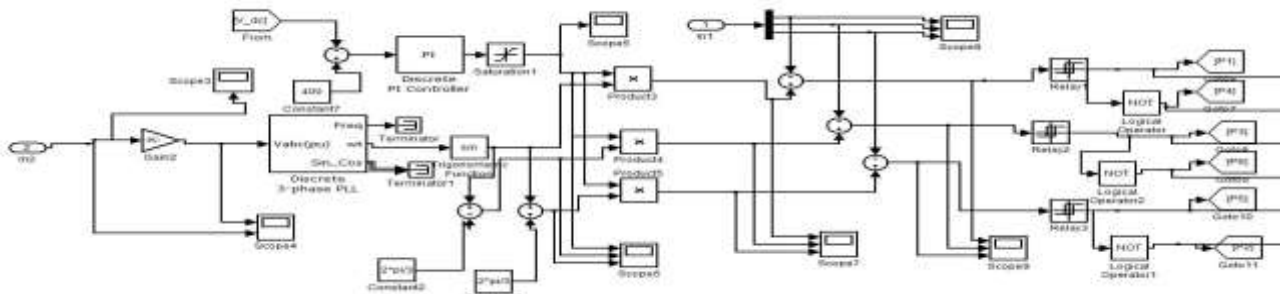
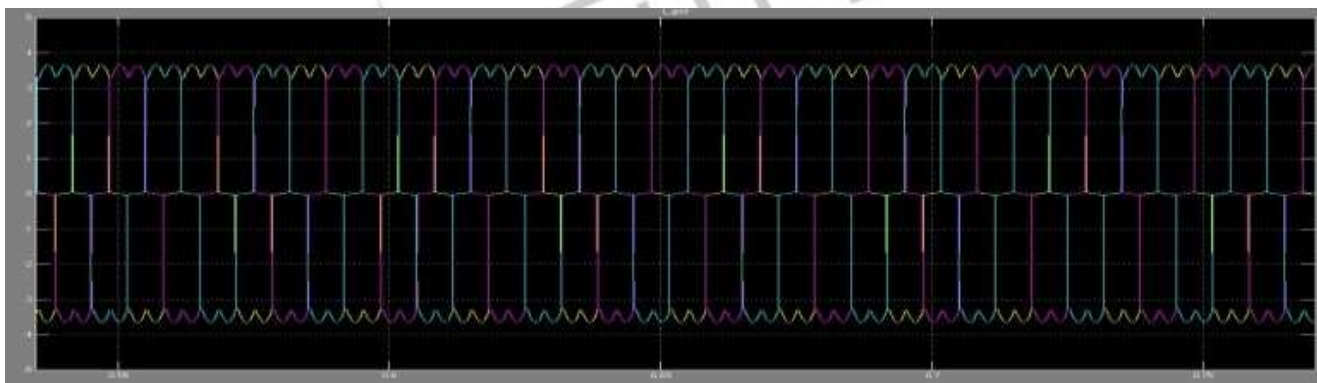

Fig.10 Simulink diagram of Hysteresis Current Controller

V. SIMULATION RESULT

Fig.11 (a) shows the supply side current when nonlinear load connected to the system without SAPF and Fig. 11 (b) shows the value of source current is 3.88A and %THD is 29.85 when nonlinear load is directly connected to three phase source without .



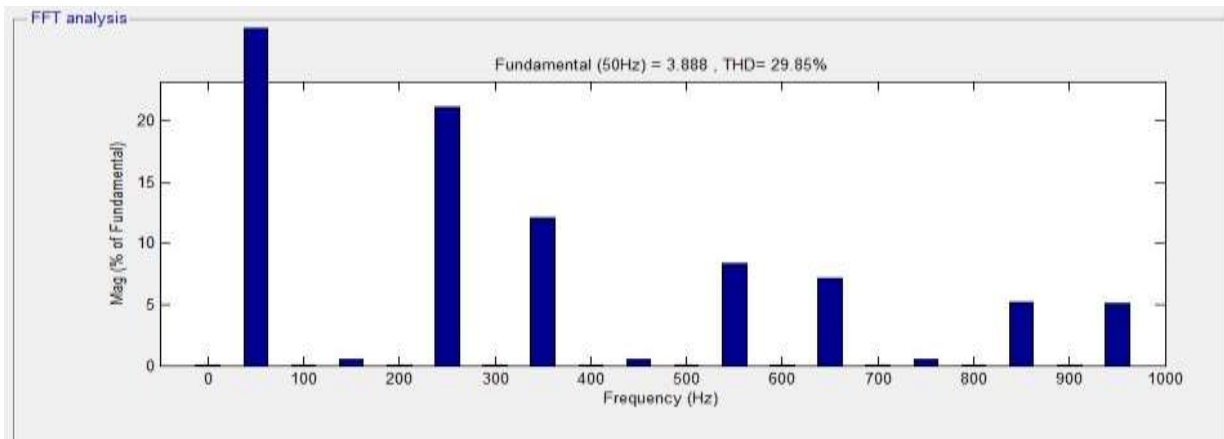

fig.11 (a) Source current of nonlinear load (b) FFT analysis source current without hysteresis controller

After application of SPWM technique to shunt APF which is connected in parallel with nonlinear load to improve source current waveform, reactive power compensation and harmonics compensation is carried out Fig.12 (a) shows the source current and Fig.12 (b) shows the %THD of shunt APF with sinusoidal pulse width modulation and it is observed that the source current is 51.03 A and %THD is 2.17% .

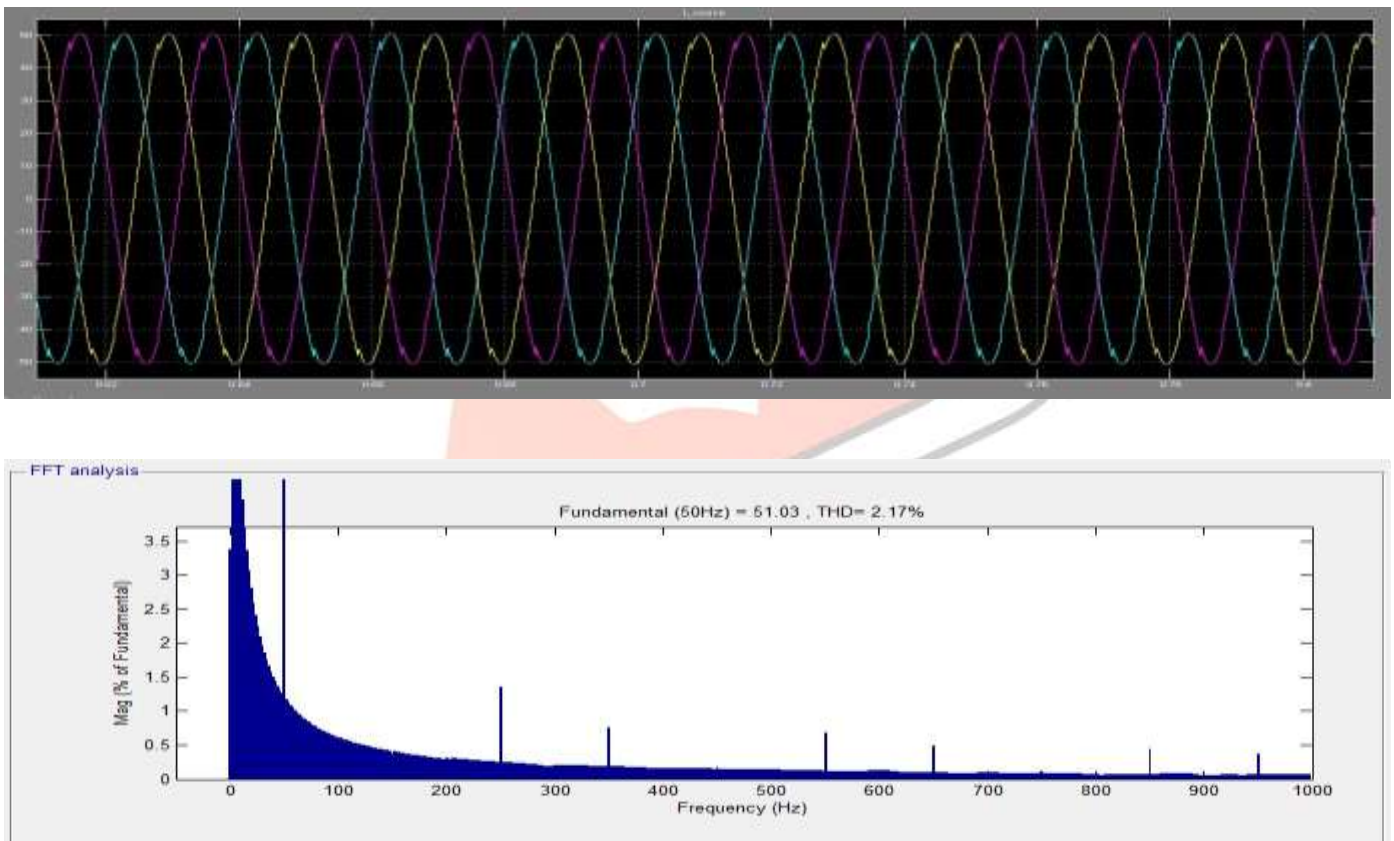

Fig.12 (a) Source current with SPWM (b) FFT analysis of source current with SPWM

Shunt APF will inject current to improve power factor and it will decrease harmonics and it will improve voltage/current waveform. Fig.13 shows the source current of three phase supply and Fig.14 shows %THD of Shunt active filter with hysteresis current controller source current is 50.94 A and % THD reduces from 29.85 to 2.84%

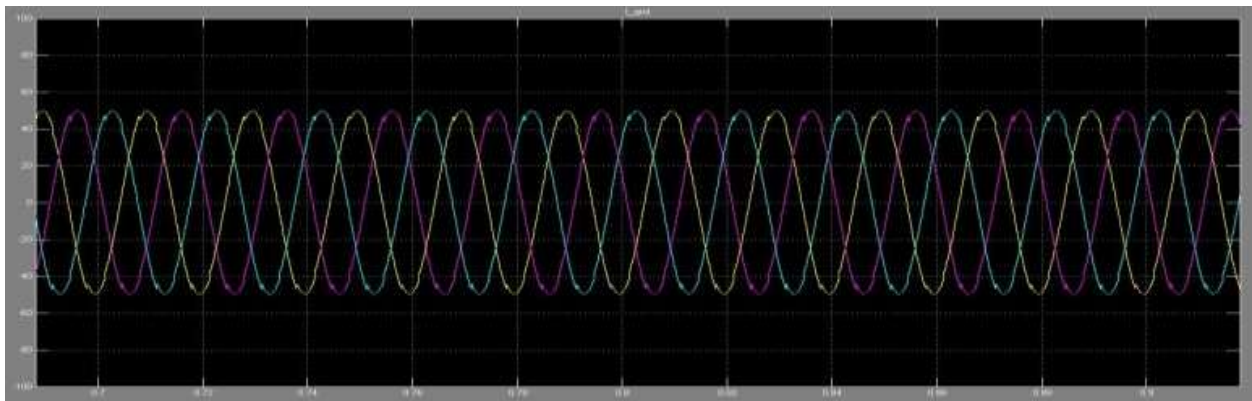

Fig.13 Source Current with Shunt Active Power Filter

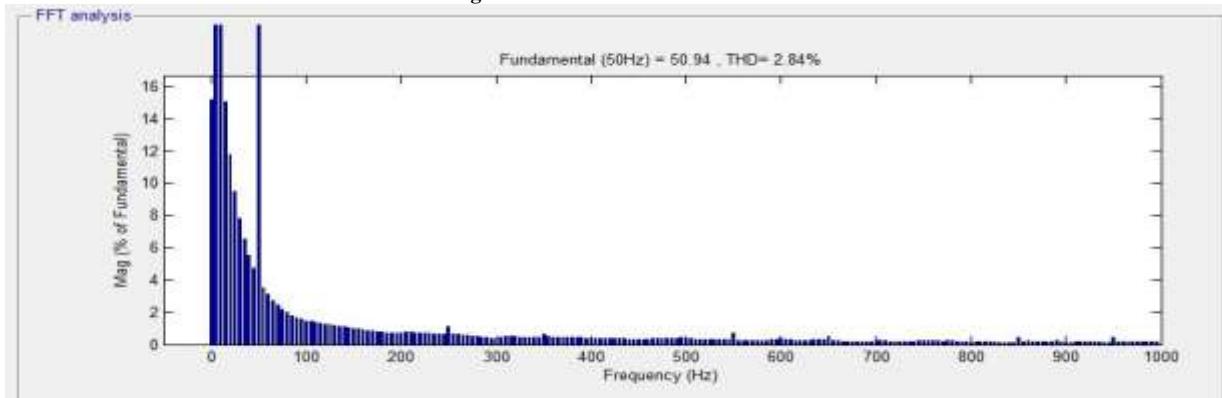

Fig.14 FFT analysis of source current with Hysteresis controller

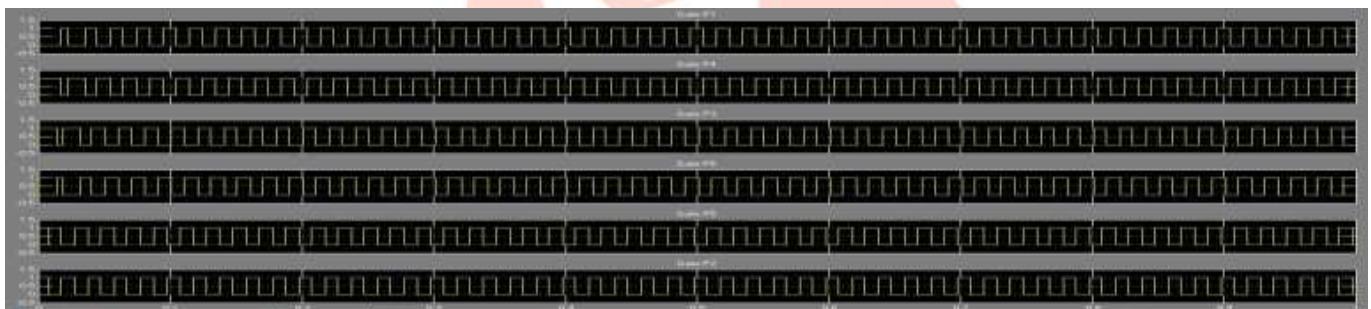

Fig.15 Switching pulses generation for IGBTs of SAPF

The switching pulses which are generated by HCC for six IGBTs are shown in Fig.14 from it we can sense when P1 is ON the same time P4 which is connected in first leg will be OFF and never two IGBTs of same leg will be ON or OFF if it Happens then it will short circuit the leg three phase inverter or shunt active power filter will malfunction.

VI COMPARATIVE ANALYSIS

Parameter	Hysteresis Controller	SPWM Controller
% THD	2.84 %	2.17 %
Complexity	less	more
Switching frequency	variable	fixed
Speed of response	fast	fast

VII. CONCLUSION

This paper presents a control technique for voltage source inverter to mitigate power quality issues. SAPF is voltage source inverter connected in parallel for reactive power compensation, harmonics compensation and power factor improvement. After simulating the nonlinear load without Shunt active power filter with shunt APF with hysteresis and sinusoidal pulse width modulation technique we observed performance analysis on the basis %THD and it is observed that it reduces as per IEEE Standard. Performance analysis based on %THD, Complexity, Switching frequency, RMS vector error & Speed of response. The performance of SPWM technique is better than the Hysteresis current control.

REFERENCES

- [1] Gayadhar Panda, Santanu Kumar Dash, Nirjharini Sahoo, "Comparative Performance Analysis of Shunt Active Power Filter and Hybrid Active Power Filter using FPGA Based Hysteresis Current Controller" Financial support provided by Department of Science and Technology (DST), Government. Of India. IEEE 2012:978- 4673-0934- 9/12/\$31.00
- [2] Naimish Zaveri, Ankit Mehta, Ajitsinh Chudasama, "Performance Analysis of Various SRF Methods in Three Phase Shunt Active Filters" IEEE 2009, 978-1-4244-4837 1/09/\$25.00, pp.442-447
- [3] B.R. Lin, T.Y. Yang, "Three-level voltage-source inverters for shunt active filter," IEE Proc.-Electr. Power Appl., Vol. 151, No. 6, November 2004.
- [4] Luigi Malesani and Paolo Tomasin, "PWM Current Control Techniques of Voltage Source Converters - A Survey," IEEE, 0-7803-0891-3/93\$03.00, 1993.
- [5] Marian P. Kaunierkowski, Maciej A. Dzieniakowski, "Review of Current Regulation Techniques For Three-phase PWM Inverters," IEEE, 0-7803-1328-3/94\$03.000, 1994.
- [6] Simone Buso, Luigi Malesani, Paolo Mattavelli, "Comparison of Current Control Techniques for Active Filter Applications," IEEE Trans. on industrial electronics, vol. 45, no. 5. October 1998.
- [7] David M. Brod, Donald W. Novotny, "Current Control of VSI-PWM Inverters," IEEE Trans. on industry applications, vol. IA-21. no. 4, may/June 1985.
- [8] Donghua Chen, Shaojun Xie "Review of the control strategies applied to active power filters," IEEE International Conference on Electric Utility Deregulation, Restructuring and Power Technologies (DRPT2004) April 2004.
- [9] Abdelmadjid Chaoui, Jean-Paul Gaubert, FatehKrim, "Power quality improvement using DPC controlled three-phase shunt active filter," Electric Power Systems Research 80 (2010) 657–666 Y. Yoro zu, M. Hirano, K. Oka, and Y. Tagawa, "Electron spectroscopy studies on magneto-optical media and plastic substrate interface," IEEE Transl. J. Magn. Japan, vol. 2, pp. 740–741, August 1987 [Digests 9th Annual Conf. Magnetics Japan, p.301, 1982].
- [10] Avik Bhattachary, Chandan Chakraborty, subhashish Bhattachary, "Reviewing Traditional Methods of Reference Current Generation," IEEE industrial electronics magazine, September 2009.
- [11] J. Chelladurai, G. SaravanaIlango, C. Nagamani, and S. Senthil Kumar, "Investigation of Various PWM Techniques for Shunt Active Filter," World Academy of Science, Engineering and Technology 39 2008
- [12] E. Hendawi, F. Khater and A. Shaltout, "Analysis, Simulation and Implementation of Space Vector Pulse Width Modulation Inverter" ISBN: 978-960-474-171-7, ISSN: 1790-2769.
- [13] Murat Kale, Engin Ozdemir, "An adaptive hysteresis band current controller for shunt active power filter" Electric Power Systems Research 73 (2005) 113–119.
- [14] T. Narongrit, K-L. Areerak and K-N. Areerak, "The Comparison Study of Current Control Techniques for Active Power Filters" World Academy of Science, Engineering and Technology 60 2011.