

New Cascaded H-Bridge Multilevel Inverter topology with reduced number of switches using artificial neural network technique

¹Parveen Nisha.M.G, ²Pauline jothi Kiruba.G.J., ³Mercy.P

¹ PG Student, ²Assistant Professor, ³Assistant Professor

¹Department of EEE

¹Info Institute of Engineering, Coimbatore, India

ABSTRACT - This paper deals Cascaded H-bridge multilevel inverter topology with reduced number of switches using artificial neural network technique. This topology consists of lower blocking voltage on switches and it requires less number of dc voltage sources, power switches which results in decrease the complexity and total cost of the inverter. A new algorithm is used to determine the magnitude of dc voltage sources for the generation of all voltage levels. Artificial Neural Network (ANN) is trained by the back-propagation algorithm of the Mean Square Error between the output and the desired value. The performances of the proposed topology using artificial neural network technique are simulated using MATLAB simulink and hardware implementation also done.

Index terms- Cascaded multilevel inverter, H-bridge, Artificial neural network, Multicarrier pulse width modulation.

I.INTRODUCTION

Multilevel inverters have received more attention used for their capability on high-power and medium voltage operation. It has advantages such as high power quality, lower order harmonics, lower switching losses, and better electromagnetic interference. It can generate a stepped voltage waveform by using number of dc voltage sources as input and proper arrangement of the power semiconductor devices. Three main structures of the multilevel inverters are “diode clamped multilevel inverter,” “flying capacitor multilevel inverter,” and “cascaded multilevel inverter”.

The disadvantage of diode clamped multilevel inverter is more complex to control. The main disadvantage of Flying Capacitor Inverter is the use of more number of capacitors will affect the voltage unbalance across capacitors. These drawbacks are overcome by a new developed topology called Cascaded H – Bridge Inverter. The cascaded multilevel inverter is composed of a number of single-phase H-bridge inverters. It is classified into symmetric and asymmetric group based on the magnitude of dc voltage sources. In symmetric type, the magnitudes of the dc voltage sources of all H-bridges are equal whereas in asymmetric type, the values of the dc voltage sources of all H-bridges are different.

A new topology of cascaded multilevel inverters is proposed to increase the number of output voltage levels and to decrease the number of power switches, driver circuits and the total cost of the inverter. In the proposed topology, the unidirectional power switches (IGBT) and (MOSFET) are used. Finally, the performances of the proposed topology using artificial neural network technique are simulated using MATLAB simulink and hardware implementation also done.

II.CASCADE MULTILEVEL INVERTER

Cascaded Multilevel Inverter consists of series H-bridge inverter units. Each bridge fed from a separate DC source. It has sixty unidirectional power switches and forty dc voltage sources. Multilevel inverter produces a desired voltage from several Separate Dc Sources (SDCSs). It is more reliable than diode clamped and flying capacitor inverter. Cascaded inverter bridge produces an output voltage ($+V_{dc}$, 0, $-V_{dc}$.)

Drawbacks:

- If voltage level increases, the number of switches also increases as a result there is large amount of power loss in the system
- The inverter is very bulky and cost of production is very high.

III.PROPOSED INVERTER

The proposed Cascade H-Bridge multilevel inverter overcomes the drawback of existing cascade 31-level inverter. In proposed topology, asymmetric type of configuration is used to generate more number of output voltage levels with the reduced number of

switches and DC voltage sources. It consists of ten unidirectional power switches (IGBT/MOSFET) and four dc voltage sources. If the power switches of $(S_{L,1}, S_{L,2})$ $(S_{L,3}, S_{L,4})$ $(S_{R,1}, S_{R,2})$ and $(S_{R,3}, S_{R,4})$ are turn on simultaneously, the dc voltage sources of $(V_{L,1}, V_{L,2}, V_{R,1}, V_{R,2})$ will be short-circuited, respectively. Therefore, the instantaneous turn-on of these switches should be avoided. In addition, S_a and S_b should not turn on simultaneously. The magnitudes of DC voltage sources are must be considered as 1P.U, 5P.U, 2P.U and 10P.U respectively.

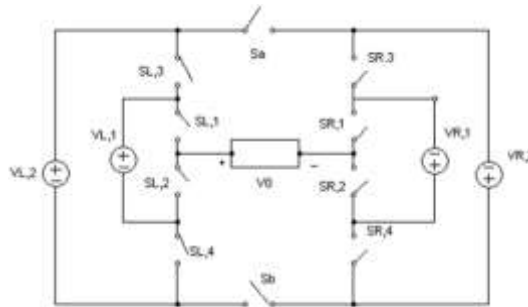

Figure 1. Circuit Diagram of Proposed Cascaded 31-level Inverter

MODES OF OPERATION

The proposed cascaded 31-level inverter circuit consists of ten unidirectional switches ($S_a, S_b, S_{L,1}, S_{L,2}, S_{L,3}, S_{L,4}, S_{R,1}, S_{R,2}, S_{R,3}, S_{R,4}$) and four DC voltage sources ($V_{L,1}, V_{L,2}, V_{R,1}, V_{R,2}$). The Thirty One Level Cascaded Multilevel Inverter has 31 modes of operation and they are as follows

(i) Mode 1

In this mode, the output voltage is $(V_{L,2}+V_{R,2})$ to generate this output voltage level, switches $S_{L,1}, S_{R,1}, S_{L,3}, S_{R,3}$ and S_b are turned on. $S_{L,2}, S_{R,2}, S_{L,4}, S_{R,4}$ and S_a are turned off.

(ii) Mode 2

In this mode, the output voltage is $(V_{L,2}+V_{R,2}-V_{L,1})$ to generate this output voltage level, switches $S_{L,1}, S_{R,2}, S_{L,3}, S_{R,3}$ and S_b are turned on. $S_{L,2}, S_{R,1}, S_{L,4}, S_{R,4}$ and S_a are turned off.

(iii) Mode 3

In this mode, the output voltage is $(V_{R,2}+V_{L,2}-V_{R,1})$ to generate this output voltage level, switches $S_{L,2}, S_{R,1}, S_{L,3}, S_{R,3}$ and S_b are turned on. $S_{L,1}, S_{R,2}, S_{L,4}, S_{R,4}$ and S_a are turned off.

(iv) Mode 4

In this mode, the output voltage is $(V_{L,2}+V_{R,2}-V_{L,1}-V_{R,1})$ to generate this output voltage level, switches $S_{L,2}, S_{R,2}, S_{L,3}, S_{R,3}$ and S_b are turned on. $S_{L,1}, S_{R,1}, S_{L,4}, S_{R,4}$ and S_a are turned off.

(v) Mode 5

In this mode, the output voltage is $(V_{L,1}+V_{R,2})$ to generate this output voltage level, switches $S_{L,1}, S_{R,1}, S_{L,3}, S_{R,4}$ and S_b are turned on. $S_{L,2}, S_{R,2}, S_{L,4}, S_{R,3}$ and S_a are turned off.

(vi) Mode 6

In this mode, the output voltage is $(V_{R,2})$ to generate this output voltage level, switches $S_{L,1}, S_{R,2}, S_{L,3}, S_{R,4}$ and S_b are turned on. $S_{L,2}, S_{R,1}, S_{L,4}, S_{R,3}$ and S_a are turned off.

(vii) Mode 7

In this mode, the output voltage is $(V_{L,1}-V_{R,1}+V_{R,2})$ to generate this output voltage level, switches $S_{L,1}, S_{R,1}, S_{L,3}, S_{R,4}$ and S_b are turned on. $S_{L,2}, S_{R,2}, S_{L,4}, S_{R,3}$ and S_a are turned off.

(viii) Mode 8

In this mode, the output voltage is $(V_{R,2}-V_{R,1})$ to generate this output voltage level, switches $S_{L,1}, S_{R,2}, S_{L,3}, S_{R,4}$ and S_b are turned on. $S_{L,2}, S_{R,1}, S_{L,4}, S_{R,3}$ and S_a are turned off.

(ix) Mode 9

In this mode, to generate output voltage level $(V_{L,2}+V_{R,1})$, switches $S_{L,1}, S_{R,1}, S_{L,4}, S_{R,3}$ and S_b are turned on. $S_{L,2}, S_{R,2}, S_{L,3}, S_{R,4}$ and S_a are turned off.

(x) Mode 10

In this mode, to generate output voltage level $(V_{L,2}+V_{R,1}-V_{L,1})$, switches $S_{L,1}$, $S_{R,2}, S_{L,4}, S_{R,3}$ and S_b are turned on. $S_{L,2}$, $S_{R,1}, S_{L,3}, S_{R,4}$ and S_a are turned off.

(xi) Mode 11

In this mode, the output voltage $(V_{L,2})$ to generate this output voltage level, switches $S_{L,2}$, $S_{R,1}, S_{L,4}, S_{R,3}$ and S_b are turned on. $S_{L,1}$, $S_{R,2}, S_{L,3}, S_{R,4}$ and S_a are turned off.

(xii) Mode 12

In this mode, the output voltage is $(V_{L,2}-V_{L,1})$ to generate this output voltage level, switches $S_{L,2}$, $S_{R,2}, S_{L,4}, S_{R,3}$ and S_b are turned on. $S_{L,1}$, $S_{R,1}, S_{L,3}, S_{R,4}$ and S_a are turned off.

(xiii) Mode 13

In this mode, the output voltage is $(V_{L,1}+V_{R,1})$ to generate this output voltage level, switches $S_{L,1}$, $S_{R,1}, S_{L,4}, S_{R,4}$ and S_b are turned on. $S_{L,2}$, $S_{R,2}, S_{L,3}, S_{R,3}$ and S_a are turned off.

(xiv) Mode 14

In this mode, the output voltage is $(V_{R,1})$ to generate this output voltage level, switches $S_{L,1}$, $S_{R,2}, S_{L,4}, S_{R,4}$ and S_b are turned on. $S_{L,2}$, $S_{R,1}, S_{L,3}, S_{R,3}$ and S_a are turned off.

(xv) Mode 15

In this mode, the output voltage is $(V_{L,1})$, to generate this output voltage level, switches $S_{L,2}$, $S_{R,1}, S_{L,4}, S_{R,4}$ and S_b are turned on. $S_{L,1}$, $S_{R,2}, S_{L,3}, S_{R,3}$ and S_a are turned off.

(xvi) Mode 16

In this mode, the output voltage is Zero to generate this output voltage level, switches $S_{L,1}$, $S_{R,1}, S_{L,3}, S_{R,3}$ and S_a are turned on. $S_{L,2}$, $S_{R,2}, S_{L,4}, S_{R,4}$ and S_b are turned off or vice versa.

(xvii) Mode 17

In this mode, the output voltage is $(-V_{L,1})$ to generate this output voltage level, switches $S_{L,1}$, $S_{R,2}, S_{L,3}, S_{R,3}$ and S_a are turned on. $S_{L,2}$, $S_{R,1}, S_{L,4}, S_{R,4}$ and S_b are turned off.

(xviii) Mode 18

In this mode, to generate output voltage level $(-V_{R,1})$, switches $S_{L,2}$, $S_{R,1}, S_{L,3}, S_{R,3}$ and S_a are turned on. $S_{L,1}$, $S_{R,2}, S_{L,4}, S_{R,4}$ and S_b are turned off.

(xix) Mode 19

In this mode, $(-V_{L,1}+V_{R,1})$ to generate this output voltage level, switches $S_{L,2}$, $S_{R,2}, S_{L,3}, S_{R,3}$ and S_a are turned on. $S_{L,1}$, $S_{R,1}, S_{L,4}, S_{R,4}$ and S_b are turned off.

(xx) Mode 20

In this mode, the output voltage is $(-V_{L,2}-V_{L,1})$, to generate this output voltage level, switches $S_{L,1}$, $S_{R,1}, S_{L,3}, S_{R,4}$ and S_a are turned on. $S_{L,2}$, $S_{R,2}, S_{L,4}, S_{R,3}$ and S_b are turned off.

(xxi) Mode 21

In this mode, to generate the output voltage level $(-V_{L,2})$, switches $S_{L,1}$, $S_{R,3}, S_{L,3}, S_{R,4}$ and S_a are turned on. $S_{L,2}$, $S_{R,2}, S_{L,4}, S_{R,2}$ and S_b are turned off.

(xxii) Mode 22

In this mode, the output voltage is $(-V_{L,2}+V_{R,1}-V_{L,1})$ to generate this output voltage level, switches $S_{L,2}$, $S_{R,1}, S_{L,3}, S_{R,4}$ and S_a are turned on. $S_{L,1}$, $S_{R,2}, S_{L,4}, S_{R,3}$ and S_b are turned off.

(xxiii) Mode 23

In this mode, the output voltage is $(-V_{L,2}+V_{R,1})$ to generate this output voltage level, switches $S_{L,2}$, $S_{R,2}, S_{L,3}, S_{R,4}$ and S_a are turned on. $S_{L,1}$, $S_{R,1}, S_{L,4}, S_{R,3}$ and S_b are turned off.

(xxiv) Mode 24

In this mode, the output voltage is $(-V_{R,2}-V_{R,1})$ to generate this output voltage level, switches $S_{L,1}$, $S_{R,1}, S_{L,4}, S_{R,3}$ and S_a are turned on. $S_{L,2}$, $S_{R,2}, S_{L,3}, S_{R,4}$ and S_b are turned off.

(xxv) Mode 25

In this mode, the output voltage is $(-V_{L,1}-V_{R,1}+V_{R,2})$ to generate this output voltage level, switches $S_{L,1}$, $S_{R,2}, S_{L,4}, S_{R,3}$ and S_a are turned on. $S_{L,2}$, $S_{R,1}, S_{L,3}, S_{R,4}$ and S_b are turned off.

(xxvi) Mode 26

In this mode, the output voltage is $(-V_{R,2})$ to generate this output voltage level, switches $S_{L,2}$, $S_{R,1}, S_{L,4}, S_{R,3}$ and S_a are turned on. $S_{L,1}$, $S_{R,2}, S_{L,3}, S_{R,4}$ and S_b are turned off.

(xxvii) Mode 27

In this mode, to generate the output voltage level $-(V_{L,1}+V_{R,2})$, switches $S_{L,2}$, $S_{R,2}, S_{L,4}, S_{R,3}$ and S_a are turned on. $S_{L,1}$, $S_{R,1}, S_{L,3}, S_{R,4}$ and S_b are turned off.

(xxviii) Mode 28

In this mode, to generate output voltage $[-(V_{L,2}+V_{R,2}-V_{L,1}-V_{R,1})]$, switches $S_{L,1}$, $S_{R,1}, S_{L,4}, S_{R,4}$ & S_a are turned on. $S_{L,2}$, $S_{R,2}, S_{L,3}, S_{R,3}$ & S_b are turned off.

(xxix) Mode 29

In this mode, the output voltage is $[-(V_{R,2}+V_{L,2}-V_{R,1})]$ to generate this output voltage level, switches $S_{L,1}$, $S_{R,2}, S_{L,4}, S_{R,4}$ and S_a are turned on. $S_{L,2}$, $S_{R,1}, S_{L,3}, S_{R,3}$ and S_b are turned off.

(xxx) Mode 30

In this mode, the output voltage is $-(V_{L,2}+V_{R,2}-V_{L,1})$ to generate this output voltage level, switches $S_{L,2}$, $S_{R,1}, S_{L,4}, S_{R,4}$ and S_a are turned on. $S_{L,1}$, $S_{R,2}, S_{L,3}, S_{R,3}$ and S_b are turned off.

(xxxi) Mode 31

In this mode, the output voltage is $-(V_{L,2}+V_{R,2})$ to generate this output voltage level, switches $S_{L,2}$, $S_{R,2}, S_{L,4}, S_{R,4}$ and S_a are turned on. $S_{L,1}$, $S_{R,1}, S_{L,3}, S_{R,3}$ and S_b are turned off.

IV. MULTICARRIER PULSE WIDTH MODULATION

Multicarrier Pulse Width Modulation is used to control the output voltage and to reduce the harmonics. The reference waveform has maximum amplitude, frequency and it is zero centered in the middle of the carrier set. The reference wave is continuously compare with each carrier signals to obtain the necessary gating pulses. If the reference wave is greater than a carrier signal, then the IGBT corresponding to that carrier be switched on and if the reference wave is less than a carrier signal, then the IGBT corresponding to that carrier be switched off. The phases of carrier signals are rearranged to produce three main disposition techniques known as PD, POD and APOD.

Phase Disposition Modulation Method (PDPWM)

In phase disposition method all the carriers have the same frequency, amplitude and are in phase. It is based on a comparison of a sinusoidal reference waveform with vertically shifted carrier waveform as shown in fig 2. In this method $(N-1)$ carrier signals are used to generate (N) level inverter output voltage. In this method fourteen triangular carrier wave have compared with the one sinusoidal reference wave.

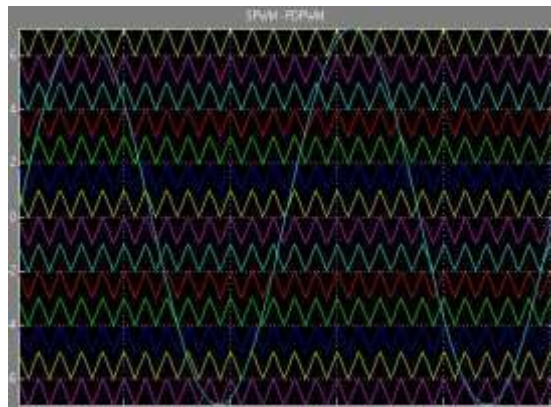

Figure 2. Phase Disposition Modulation

V. ARTIFICIAL NEURAL NETWORK TECHNIQUE

Artificial neural network is an adaptive system that changes structure based on external or internal information which flows throughout the network during the learning phase. Neural networks are non-linear statistical data modeling tools. They can be used as model complex relationships between inputs and outputs to find data patterns. The Artificial neural network is trained by the back-propagation algorithm of the Mean Square Error (MSE) between the output and the desired value. The training set for the network has been produced off-line by solving these non-linear equations using Newton-Raphson method.

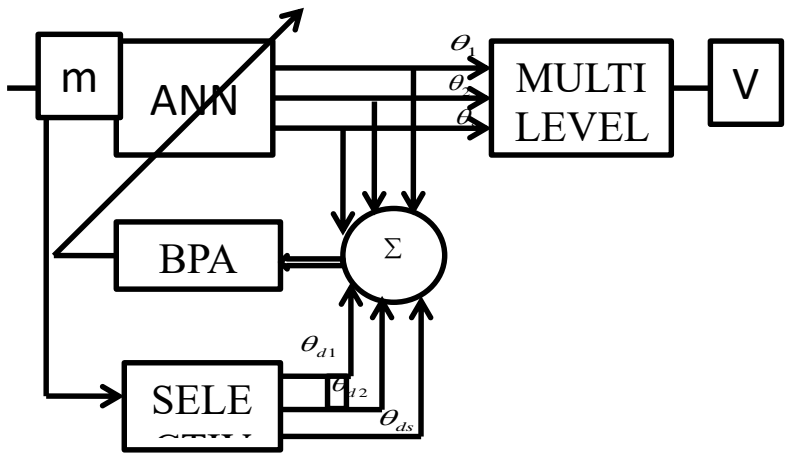

Figure 3. Back Propagation Algorithm

To implement this algorithm, MATLAB programming is used which in turn makes the process fast and easy. When a set of input values are presented in the ANN, step by step calculations are made in forward direction to drive the output pattern. The mean square error (MSE) generated for the set of input patterns, it is minimized by gradient descent method altering the weights one at a time starting from the output layer. After the termination of training phase, the obtained ANN is used to generate the control sequence of the inverter. ANN is also used for the generation of the optimal switching angles, which has a single input neuron fed by the modulation index, one hidden layer and s outputs where each output represents a switching angle. This set of angles is required to eliminate the 5th, 7th, 11th and 13th harmonics, etc,

VI. SIMULATION RESULTS

Cascaded H-Bridge Multilevel Inverter by Artificial Neural Network Technique is designed and simulated using the MATLAB/SIMULINK Software. Based on DC source algorithm, if the magnitude of $(V_{L,i})$ considered as 15 V, then the magnitudes of other dc voltage sources will be 30, 75, and 150 V, which are related to $(V_{R1}, V_{L2}, \text{ and } V_{R2})$ respectively. Now, the magnitude of (V_{R1}) DC source is changed as 40V and the THD will be 5.64%. Fig: 5 shows the voltage of ANN is 225V and current of are 22.5 Ampere waveform of Cascade H-Bridge 31-Level inverter. Fig: 4 show the simulink model of artificial neural network technique for cascaded H-Bridge multilevel inverter. Table (1) shows the system parameters used for simulation. Table (3) shows the switching patterns and output voltages of each level of Cascaded H-Bridge 31-level Inverter.

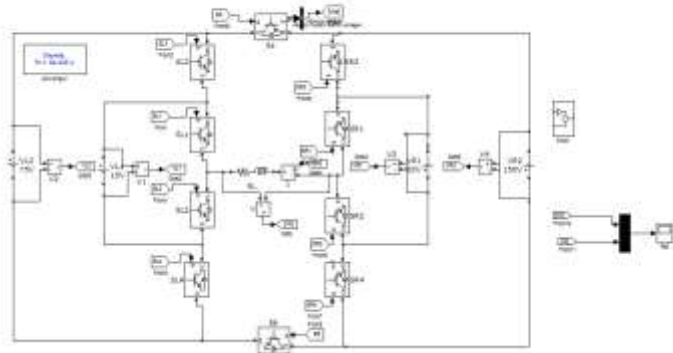

Figure 4. Simulink Model of Artificial Neural Network Technique for Cascaded H-Bridge 31-Level Inverter

Table 1. Parameters and Values of Cascaded H-Bridge 31-Level Inverter

S.NO	Parameters	Values of simulation
1	DC supply voltage (V_{dc})	270V
2	Inductance (L)	49×10^{-3} H
3	Switching frequency	50 HZ
4	Snubber Resistance (R_s)	148 Ω
5	Diode Resistance (R_d)	0.05 Ω
6	Output voltage	225V
7	Load Resistance	10 Ω

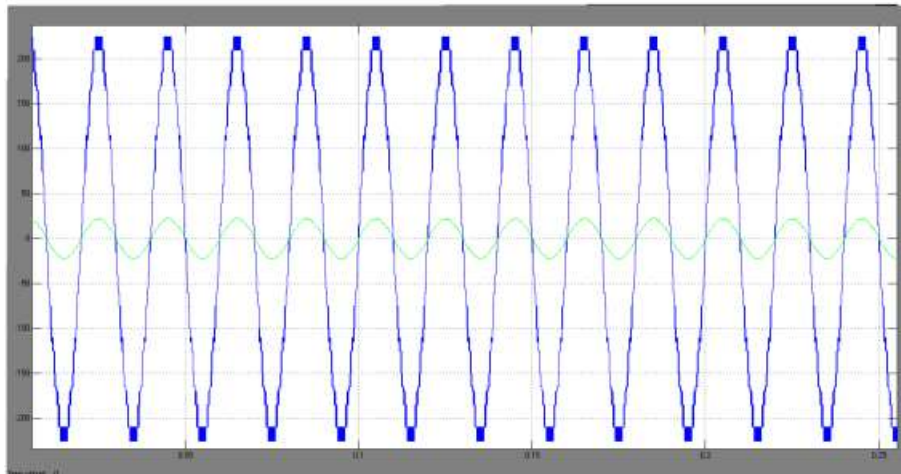

Figure 5. Output Voltages and Current of Inverter

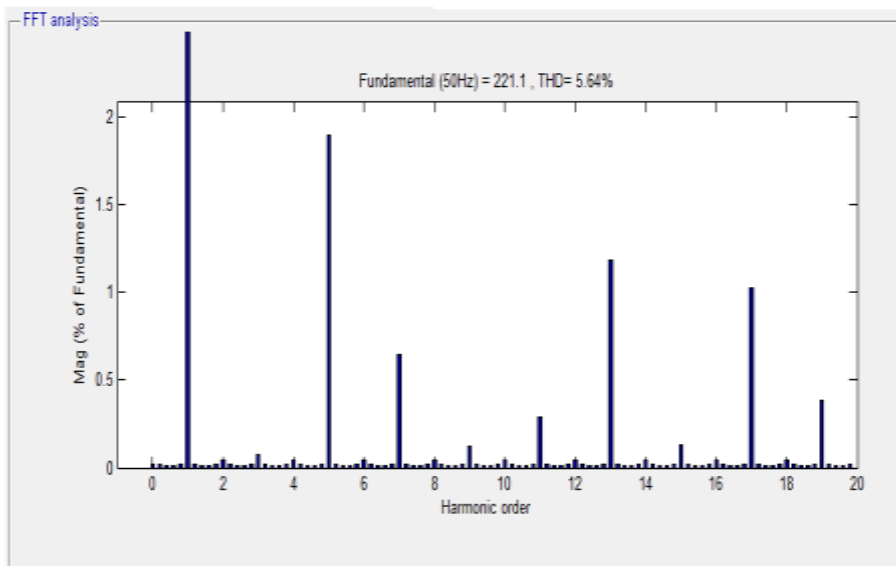

Figure 6. THD Analysis of Inverter

Table 2. Comparison of THD Analysis

S.NO	Magnitude of DC source	THD of existing cascade H-Bridge 31-level Inverter	THD of proposed cascade H-Bridge 31-level Inverter
1	$V_{L,1}=15V, V_{L,2}=65V, V_{R,1}=30V, V_{R,2}=150V$	5.11%	4.72%
2	$V_{L,1}=15V, V_{L,2}=65V, V_{R,1}=40V, V_{R,2}=150V$	6.14%	5.56%
3	$V_{L,1}=15V, V_{L,2}=75V, V_{R,1}=40V, V_{R,2}=150V$	5.81%	5.64%
4	$V_{L,1}=15V, V_{L,2}=75V, V_{R,1}=40V, V_{R,2}=160V$	5.12%	5.01%
5	$V_{L,1}=15V, V_{L,2}=65V, V_{R,1}=30V, V_{R,2}=160V$	5.84%	5.39%
6	$V_{L,1}=15V, V_{L,2}=65V, V_{R,1}=50V, V_{R,2}=170V$	7.88%	7.56%
7	$V_{L,1}=15V, V_{L,2}=65V, V_{R,1}=50V, V_{R,2}=150V$	9.27%	8.64%

represents analysis of proposed cascaded H-bridge 31-level inverter with different combination of change in magnitude of DC voltage source.

Table (2) the THD existing and

Table 3. Switching Patterns and Output Voltages of the 31-level Inverter

NO	$S_{L,1}$	$S_{L,2}$	$S_{L,3}$	$S_{L,4}$	$S_{R,1}$	$S_{R,2}$	$S_{R,3}$	$S_{R,4}$	S_a	S_b	V_0
1	1	0	1	0	1	0	1	0	0	1	$V_{L,2}+V_{R,2}$
2	1	0	1	0	0	1	1	0	0	1	$V_{L,2}+V_{R,2}-V_{L,1}$
3	0	1	1	0	1	0	1	0	0	1	$V_{R,2}+V_{L,2}-V_{R,1}$
4	0	1	1	0	0	1	1	0	0	1	$(V_{L,2}+V_{R,2}-V_{L,1}-V_{R,1})$
5	1	0	1	0	1	0	0	1	0	1	$V_{L,1}+V_{R,2}$
6	1	0	1	0	0	1	0	1	0	1	$V_{R,2}$
7	0	1	1	0	1	0	0	1	0	1	$V_{L,1}-V_{R,1}+V_{R,2}$
8	0	1	1	0	0	1	0	1	0	1	$V_{R,2}-V_{R,1}$
9	1	0	0	1	1	0	1	0	0	1	$V_{L,2}+V_{R,1}$
10	1	0	0	1	0	1	1	0	0	1	$V_{L,2}+V_{R,1}-V_{L,1}$
11	0	1	0	1	1	0	1	0	0	1	$V_{L,2}$
12	0	1	0	1	0	1	1	0	0	1	$V_{L,2}-V_{L,1}$
13	1	0	0	1	1	0	0	1	0	1	$V_{L,1}+V_{R,1}$
14	1	0	0	1	0	1	0	1	0	1	$V_{R,1}$
15	0	1	0	1	1	0	0	1	0	1	$V_{L,1}$
16	1	0	1	0	1	0	1	0	1	0	0
	0	1	0	1	0	1	0	1	0	1	0
17	1	0	1	0	0	1	1	0	1	0	$-V_{L,1}$
18	0	1	1	0	1	0	1	0	1	0	$-V_{R,1}$
19	0	1	1	0	0	1	1	0	1	0	$-(V_{L,1}+V_{R,1})$
20	1	0	1	0	1	0	0	1	1	0	$-(V_{L,2}-V_{L,1})$
21	1	0	1	0	0	1	0	1	1	0	$-V_{L,2}$
22	0	1	1	0	1	0	0	1	1	0	$-(V_{L,2}+V_{R,1}-V_{L,1})$

23	0	1	1	0	0	1	0	1	1	0	$-(V_{L,2}+V_{R,1})$
24	1	0	0	1	1	0	1	0	1	0	$-(V_{R,2}-V_{R,1})$
25	1	0	0	1	0	1	1	0	1	0	$-(V_{L,1}-V_{R,1}+V_{R,2})$
26	0	1	0	1	1	0	1	0	1	0	$-V_{R,2}$
27	0	1	0	1	0	1	1	0	1	0	$-(V_{L,1}+V_{R,2})$
28	1	0	0	1	1	0	0	1	1	0	$-(V_{L,2}+V_{R,2}-V_{L,1}-V_{R,1})$
29	1	0	0	1	0	1	0	1	1	0	$-(V_{R,2}+V_{L,2}-V_{R,1})$
30	0	1	0	1	1	0	0	1	1	0	$-(V_{L,2}+V_{R,2}-V_{L,1})$
31	0	1	0	1	0	1	0	1	1	0	$-(V_{L,2}+V_{R,2})$

VII. HARDWARE IMPLEMENTATION

The hardware of a cascaded H-bridge multilevel inverter for generating 31-level output voltages is designed as shown in fig.7, based on the parameters listed in Table 4. The switching time at 25ms. The PIC 16F877A microcontroller is used for firing pulse generation. There are MOSFET switches are used for the hardware configuration. This unit consists of transformer, rectifier, filter, regulator, opto coupler and IC 7667. AC voltage typically of 230Vrms is connected to a transformer which steps that AC voltage down to the desired AC voltage level. A diode rectifier gives full wave rectified voltage that is initially filtered by a simple capacitor filter to produce a DC voltage. The magnitudes of Dc voltage sources will be 6V, 12V, 30V, and 60 V which are related to $V_{L,1}$, $V_{R,1}$, $V_{L,2}$, and $V_{R,2}$, respectively. This resulting DC voltage usually has some ripple or AC voltage variations. Regulator circuit can use this DC input to provide DC voltage that not only has much less ripple voltage but also remains in the same DC value, even when the DC voltage varies, or the load connected to the output DC voltage changes. The required DC supply is obtained from the available AC supply after rectification, filtration and regulation. Fig 8 shows, Output voltage pulse of cascaded H-bridge multilevel inverter with 31-voltage levels.

Table 4 Hardware System Parameters

SYSTEM PARAMETERS	VALUES
AC Supply Voltage	230V
Stepping Down Voltage	Constant (5V,6V,12V,30V,60V)
Voltage Regulator	IC7805
PIC Microcontroller	PIC16F877A
DC output Voltage	5V



Figure 7. Hardware Experimental setup

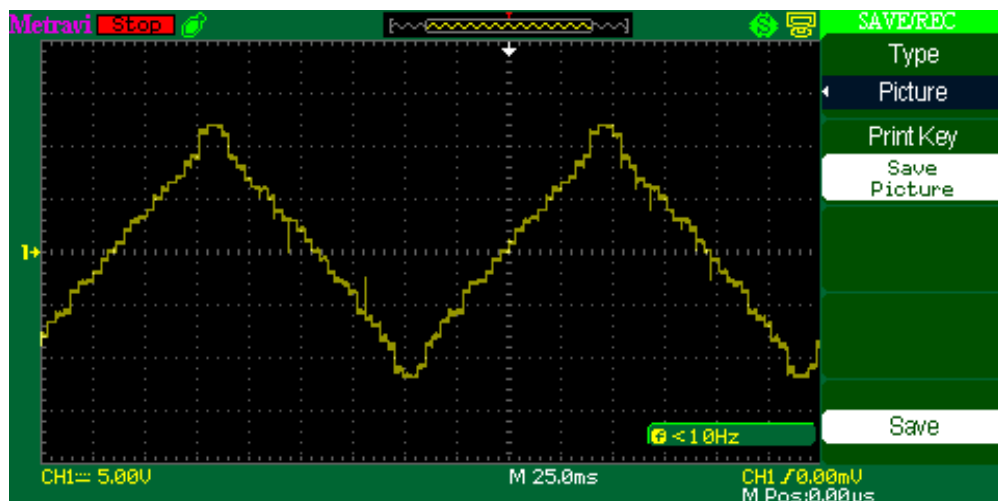

Figure 8 output voltage of cascaded H-bridge multilevel inverter (31-levels)

VIII. CONCLUSION

This paper deals Cascaded H-bridge multilevel inverter topology with reduced number of switches using artificial neural network technique. The proposed topology was compared with the different kinds of presented topologies from different points of view. According to the comparison results, the proposed topology requires a lesser number of switches, driver circuits, and DC voltage sources. Multicarrier Pulse Width Modulation method is used to control Cascaded H-Bridge Multilevel Inverter. Artificial neural network technique is used to control the output voltage and to reduce the harmonics. If the magnitude of DC sources changes, it will affect the output voltage and increases the THD value. The THD value is 5.64% and output voltage is 225V. From the hardware implementation, AC voltage typically of 230Vrms is connected to a transformer which steps that AC voltage down to the desired AC voltage level. A diode rectifier gives full wave rectified voltage that is initially filtered by a simple capacitor filter to produce a DC voltage. The magnitudes of DC voltage sources will be 6V, 12V, 30V, and 60V which are related to $V_{L,1}$, $V_{R,1}$, $V_{L,2}$, and $V_{R,2}$, respectively. IC7805 is a fixed voltage regulators used in this circuit. From the hardware output DC supply voltage is 5V. The performance accuracy of the Cascaded H-Bridge 31-level inverter was verified through the MATLAB/SIMULINK and experimental results.

REFERENCES

- [1]. K. Wang, Y. Li, Z. Zheng, and L. Xu, "Voltage balancing and fluctuation suppression methods of floating capacitors in a new modular multilevel converter," *IEEE Trans. Ind. Electron.*, vol. 60, no. 5, pp. 1943–1954, May 2013.
- [2]. E. Babaei and S. H. Hosseini, "Charge balance control methods for asymmetrical cascade multilevel converters," in *Proc. ICEMS*, Seoul, Korea, 2007, pp. 74–79.
- [3]. J. Ebrahimi, E. Babaei, and G. B. Gharehpetian, "A new topology of cascaded multilevel converters with reduced number of components for high-voltage applications," *IEEE Trans. Power Electron.*, vol. 26, no. 11, pp. 3109–3118, Nov. 2011.
- [4]. M. Narimani and G. Moschopoulos, "A novel single-stage multilevel type full-bridge converter," *IEEE Trans. Ind. Electron.*, vol. 60, no. 1, pp. 31–42, Jan. 2013.
- [5]. N. Abd Rahim, M. F. Mohamad Elias, and W. P. Hew, "Transistor-clamped H-bridge based cascaded multilevel inverter with new method of capacitor voltage balancing," *IEEE Trans. Ind. Electron.*, vol. 60, no. 8, pp. 2943–2956, Aug. 2013.
- [6]. M. Farhadi Kangarlu and E. Babaei, "A generalized cascaded multilevel inverter using series connection of sub multilevel inverters," *IEEE Trans. Power Electron.*, vol. 28, no. 2, pp. 625–636, Feb. 2013.
- [7]. S. R. Pulikanti, G. Konstantinou, and V. G. Agelidis, "Hybrid seven-level cascaded active neutral-point-clamped-based multilevel converter under SHE-PWM," *IEEE Trans. Ind. Electron.*, vol. 60, no. 11, pp. 4794–4804, Nov. 2013.
- [8]. Y. Hinago and H. Koizumi, "A single-phase multilevel inverter using switched series/parallel dc voltage sources," *IEEE Trans. Ind. Electron.*, vol. 57, no. 8, pp. 2643–2650, Aug. 2010.
- [9]. E. Babaei, M. Farhadi Kangarlu, and F. Najaty Mazgar, "Symmetric and asymmetric multilevel inverter topologies with reduced switching devices," *Elect. Power Syst. Res.*, vol. 86, pp. 122–130, May 2012.
- [10]. J. Ebrahimi, E. Babaei, and G. B. Gharehpetian, "A new multilevel converter topology with reduced number of power electronic components," *IEEE Trans. Ind. Electron.*, vol. 59, no. 2, pp. 655–667, Feb. 2012.